



Capacity



16 KG

+90°C → +3°C



10 KG

+90°C → -18°C

Trays

GN 1/1 Food pans
600 mm x 400 mm

5

5 Litre Ice cream pans
165x360xH120

6

Trays Pitch

68 mm

Options



STERILIZING OZONE



PASTRY TRAYS (STEP 10 mm)



CASTORS KIT 898 mm(H)
ROLLERS KIT 870 mm(H)



HACCP INTERNAL DATA
STORAGE CARD WITH
BUILT IN USB PORT

Features

| | |
|-----------------------------------|----------------|
| Power supply | 230V/1N/50HZ |
| Code number | BK5-16 |
| Outside length | 800 mm |
| Height | 900-930 mm |
| Depth | 700 mm |
| Capacity | 600x400 GN 1/1 |
| Compressor | HERMETIC |
| Refrigeration Power (-10°C/+45°C) | 1573 |
| Refrigeration Fluid | 1100 g - R404A |
| Output chilling (+90°C/+3°C) | 16 |
| Output freezing (+90°C/-18°C) | 10 |
| Electronic card | BASE |
| Absorbed power | 1250 W - 5,8 A |
| Weight net/gross | 108/123 kg |

from the world of Comcater!

National Head Office
156 Swann Drive
Derrimut VIC 3030
Tel: +61 3 8369 4600
Fax: +61 3 8369 4695

Melbourne
96-100 Tope Street
South Melbourne VIC 3205
Tel: +61 3 8369 4600
Fax: +61 3 8699 1299

Sydney
20/4 Avenue of the Americas
Newington, NSW 2127
Tel: +61 2 9748 3000
Fax: +61 2 9648 4762

Brisbane
1/62 Borthwick Avenue
Murarrie QLD 4172
Tel: +61 7 3399 3122
Fax: +61 7 3399 5311

Perth
Unit 4/35 Westchester Road
Malaga WA 6090
Tel: +61 8 9248 9290
Fax: +61 8 9248 1903



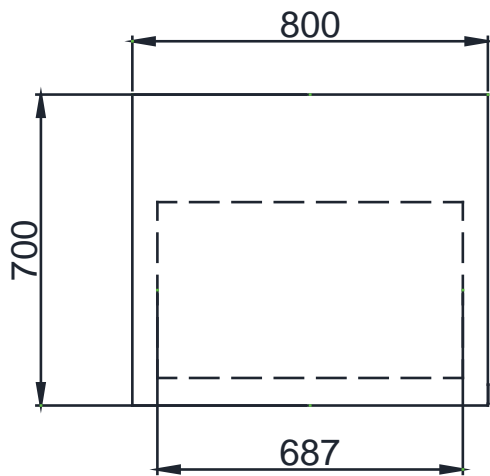
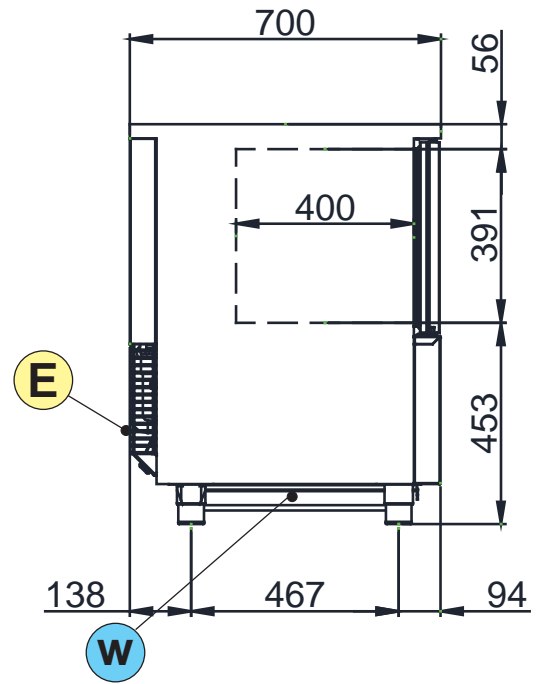
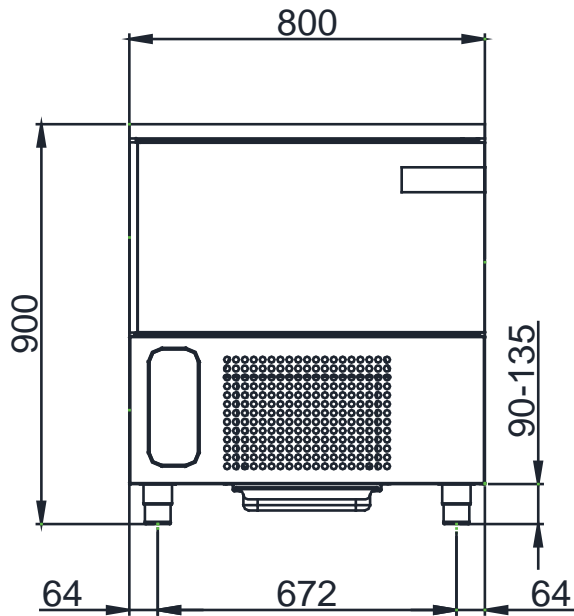

CONTROL PANEL



DRAINAGE DISCHARGE



ELECTRICAL CABLE SUPPLY