

# HTM145SDSS

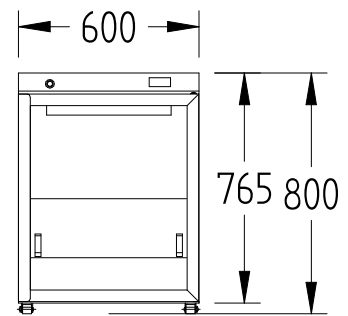

CATEGORY	TOPAZ CAFÉ RANGE
RANGE	<b>Topaz Milk</b>
UNIT	REFRIGERATOR
TYPE	SELF CONTAINED
DOOR	1

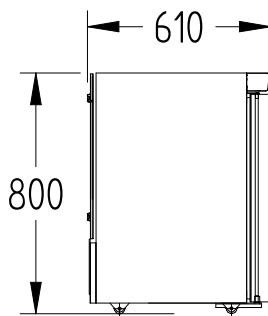

## SPECIFICATIONS

CAPACITY LITRES	145
TEMPERATURE - 32°C AMBIENT ENVIRONMENT	1°C / 4°C
DIMENSIONS - W X D X H MM	600 W x 610 D x 800 H
WEIGHT UNPACKED (KG)	55
DOOR TYPE	Standard: SD (Solid Door)
FINISH (INTERIOR AND EXTERIOR EXCLUDING REAR AND UNDER)	SS (Stainless Steel)
SHELVES	2
<b>ELECTRICAL</b>	
POWER SUPPLY	10 amp
POWER CABLE LENGTH (METRES)	2
RUNNING AMPS	1.0
<b>GAS TYPE</b>	
REFRIGERANT	R134a

\*\*\* For **OPTIONS** refer to the current Williams Price Guide