

LTG1SS

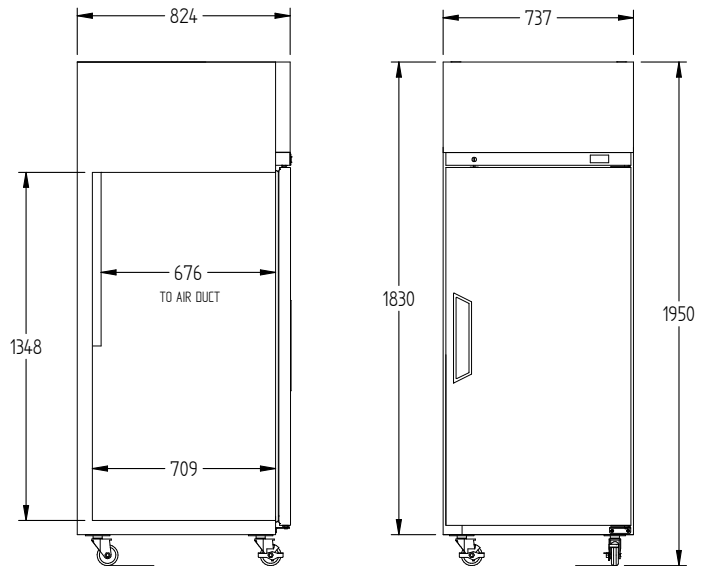

CATEGORY	TOPAZ CAFÉ RANGE
RANGE	Topaz Top Mount
UNIT	FREEZER
TYPE	SELF CONTAINED
DOORS	1

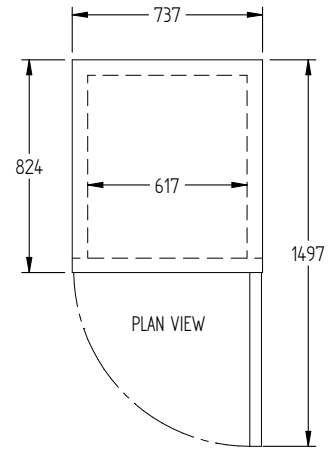

SPECIFICATIONS

TEMPERATURE - 36°C AMBIENT ENVIRONMENT	-18°C / -22°C
CAPACITY LITRES	580
DIMENSIONS - W X D X H MM	737 W x 824 D x 1950 H
WEIGHT UNPACKED (KG)	170
STANDARD INCLUSIONS*	
DOOR TYPE	S (SOLID DOOR)
FINISH (INTERIOR AND EXTERIOR EXCLUDING REAR AND UNDER)	S (STAINLESS STEEL)
SHELVES/DOOR	4
ELECTRICAL	
POWER SUPPLY	10amp
POWER CABLE LENGTH (METRES)	2
RUNNING AMPS	3.3
GAS TYPE	
REFRIGERANT	R404a

*** For **OPTIONS** refer to the current Williams Price Guide