

## Controlled Ambient Integral 3000 Series 800/1200/1500/1800

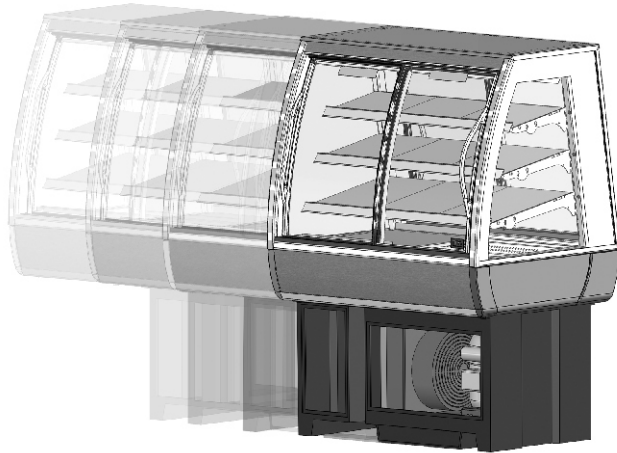

Designed with price in mind these cabinets suit the smaller café, kiosk and C-store. The Inline 3000 still comes with many of the features associated with the higher priced models such as moving air refrigeration. The Inline 3000's unique construction allows the cabinet to be counter mounted. The Inline 3000 comes packed with features to enhance food presentation.

### OPTIONS:



slide door



fixed front

### FEATURES

- Stainless steel construction
- Toughened double glazed glass
- Front sliding doors (SD)
- Fixed front (FF)
- Rear sliding doors
- Cabinet top lighting
- Adjustable shelving
  - Height : 25.4mm Increments
  - Angle : Flat or 10° Pitch
- Stainless steel flat trays
- Shelf mounted ticket strip, front and rear
- Moving air refrigeration maintains cabinet temperature of 15-17°C with up to 60 door openings per hour
- Integral condenser housed in Rotomold bin
- Automatic defrost cycle
- Counter integration options
  - counter top
  - recessed

### ACCESSORIES

#### Factory Fitted Accessories

- Shelf lighting
- Condensate evaporator tray

#### Standard Accessories

- Small goods trays
- Angled base shelf
- Thermal divider panel - Prevents heat transfer between heated and refrigerated cabinets



refrigerated



controlled ambient



ambient



heated



bain marie

### COMPLIANCE & APPROVALS



MEPS



HACCP

Australia  
T 1800 813 745  
F 1800 813 746  
E ausales@fpgworld.com  
142 Proximity Drive  
Sunshine, P O Box 5062  
Vic 3020  
Australia

China/Asia  
T +86 21 5284 9755  
F +86 21 3633 1611  
E asales@fpgworld.com  
Rm 104, Building 8  
No.31 KaiXuan Road (S)  
Shanghai 200232  
P R China

New Zealand  
T +64 6 843 3249  
F +64 6 843 2466  
E nzsales@fpgworld.com  
110 Austin Street  
P O Box 3029  
Napier, 4112  
New Zealand

United Kindom  
T 0800 234 7922  
F 0808 234 7921  
E uksales@fpgworld.com  
80 Haymarket  
London SW1Y4TQ  
United Kingdom

Europe  
T +49 89 7190 9062  
F +49 89 7190 9063  
E eusales@fpgworld.com  
20a Kreggerheim Straße  
München 81377  
Germany

**FPG**  
food display ■ retail solutions

## Controlled Ambient Integral 3000 Series

800/1200/1500/1800

SPECIFICATIONS				
	3CA08	3CA12	3CA15	3CA18
Height	769mm	769mm	769mm	769mm
Width	803mm	1203mm	1503mm	1803mm
Depth	663mm	663mm	663mm	663mm
Dry Weight	80Kg	100Kg	130Kg	160Kg
Temp Range	15-17°C	15-17°C	15-17°C	15-17°C
No. of Shelves	3 + Base	3 + Base	3 + Base	3 + Base
Display Area	0.9 m <sup>2</sup>	1.40m <sup>2</sup>	1.80m <sup>2</sup>	2.20m <sup>2</sup>
Voltage	230-240V	230-240V	230-240V	230-240V
Power	0.63Kw	0.69Kw	0.86Kw	1.20Kw
Typical Current	2.75Amps	2.98Amps	3.72Amps	5.22Amps
Connection	10 Amp 3 Pin Plug	10 Amp 3 Pin Plug	10 Amp 3 Pin Plug	10 Amp 3 Pin Plug
Refrigerant	R134a	R134a	R134a	R134a
Climatic Class & IP	Class N, IP22	Class N, IP22	Class N, IP22	Class N, IP22
SHIPPING (Crated)				
Height	1330mm	1330mm	1330mm	1330mm
Width	875mm	1280mm	1580mm	1880mm
Depth	755mm	755mm	755mm	755mm
Weight	160Kg	205Kg	235Kg	247Kg
Volume	0.88m <sup>3</sup>	1.26m <sup>3</sup>	1.58m <sup>3</sup>	1.94m <sup>3</sup>



refrigerated



controlled ambient



ambient



heated



bain marie

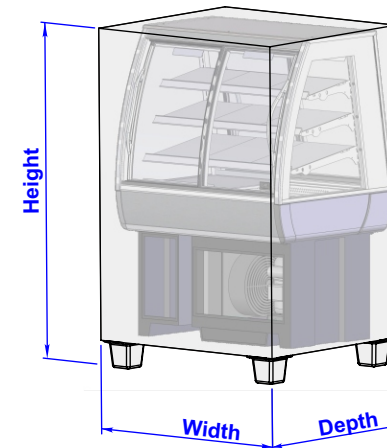

2  
3CATS-REVA



## Controlled Ambient Integral 3000 Series 800/1200/1500/1800

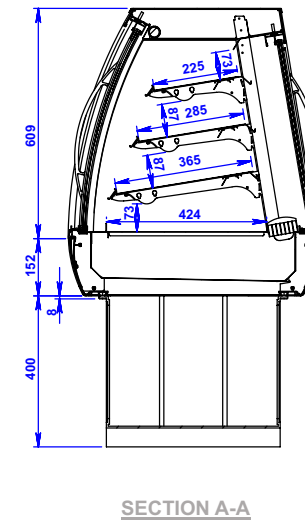
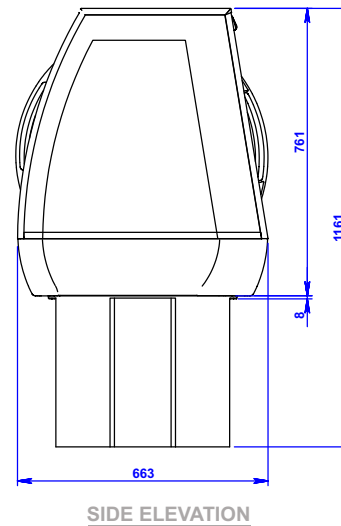
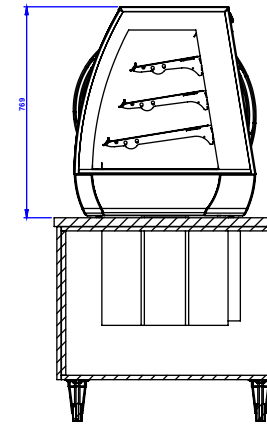
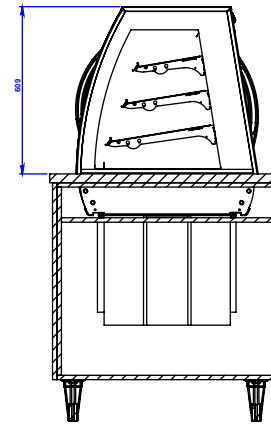
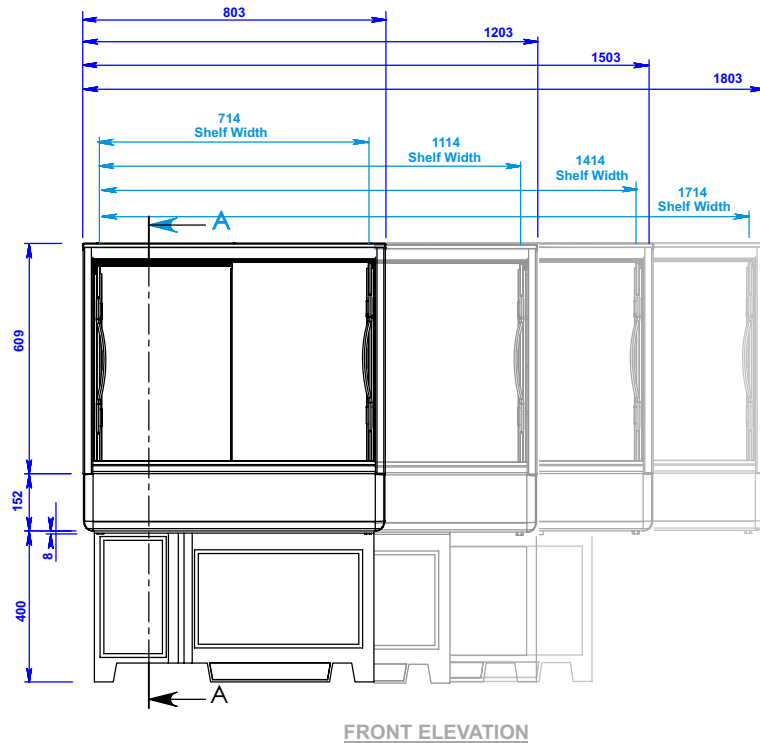

refrigerated



controlled ambient



ambient



heated



bain marie

3  
3CATS-REVA

