

THE HIGH h BATCH

HIGH h BATCH

EXTERIOR CONSTRUCTION

- 430 stainless steel front, top, sides and back
- 4" (102 mm) adjustable legs
- Cool to touch coated door handle
- Removable drain pan
- Removable cook door for cleaning

INTERIOR CONSTRUCTION

- 304 stainless steel interior
- Drain system helps prevent debris buildup
- High-coverage Jetplates for customized cooking results

STANDARD FEATURES

- Integral recirculating catalytic converter for UL listed ventless operation (UL KNLZ)
- Configurable top and bottom Jetplates for product specific cooking
- Variable speed High h recirculating impingement airflow system
- Oscillating rack for high heat transfer without spotting
- Half-sheet pan/16-inch pizza capacity
- Smart Voltage Sensor Technology* (U.S. only)
- Stackable design (requires stacking kit)
- Smart Menu System capable of storing up to 72 recipes
- Includes plug and cord (5 ft.)
- Warranty – 1 year parts and labour



PERFORMANCE

- Heat transfer rates (h) are 3X-4X typical convection oven
- Heat transfer rates (h) are 2X typical conveyor oven
- The High h Batch offers full baking capabilities up to 5x faster than traditional equipment, achieving conveyor-type results in a compact size

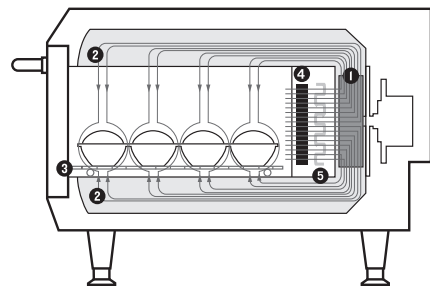

1. Blower Motor
2. Air Impingement
3. Oscillating Rack
4. Catalytic Converter
5. Impingement Heater



*Smart Voltage Sensor Technology does not compensate for lack of or over voltage situations.
It is the responsibility of the owner to supply voltage to the unit according to the above specifications.
**This product conforms to the ventilation recommendations set forth by NFPA96 using EPA202 test method.



Accelerating the World of Cooking™



Accelerating the World of Cooking™

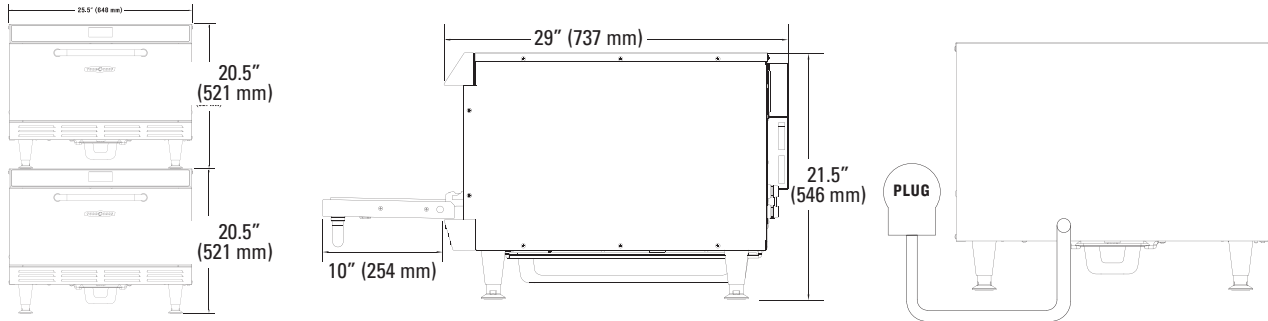

DIMENSIONS		
Single Units		
Height	20.5"	(521 mm)
Width	25.5"	(648 mm)
Depth	29"	(737 mm)
with handle	31.5"	(800 mm)
Weight	157 lbs.	(71 kg)
Stacked Units (Stacking Kit Required) (No Legs)		
Height	41"	(1041 mm)
Width	25.5"	(648 mm)
Depth	29"	(737 mm)
with handle	31.5"	(800 mm)
Weight	314 lbs.	(142 kg)
Cook Chamber		
Height	8"	(203 mm)
Width	18.75"	(476 mm)
Depth	16.75"	(425 mm)
Volume	1.45 cu. ft.	(41.1 liters)
Wall Clearance		
Top/Sides	2"	(51 mm)

ELECTRICAL SPECIFICATIONS		
EUROPE/ASIA/PACIFIC/AUSTRALIA		
HHBEW (HHB-8602-1W)		
Phase	3 Phase	
Voltage	400 VAC	
Frequency	50/60 Hz	
Current	10 amp	
Cord	HO7RN-F, 5 wire	
Plug	IEC 309, 5-PIN, 16 AMP	
Max Input	5.0 watts	
HHBED (HHB-8602-1D)		
Phase	3 Phase	
Voltage	230 VAC	
Frequency	50/60 Hz	
Current	18 amp	
Cord	HO7RN-F, 4 wire	
Plug	IEC 309, 4-PIN, 32 AMP	
Max Input	5.0 watts	
HHBUK (HHB-8602-1K)		
Phase	1 Phase	
Voltage	230 VAC	
Frequency	50/60 Hz	
Current	24 amp	
Cord	HO7RN-F, 3 wire	
Plug	IEC 309, 3-PIN, 32 AMP	
Max Input	5.0 watts	



Australia
www.moffat.com.au
New Zealand
www.moffat.co.nz

Australia
Moffat Pty Limited
Victoria/Tasmania
740 Springvale Road
Mulgrave, Victoria 3170
Telephone 03-9518 3888
Facsimile 03-9518 3833
Email vsales@moffat.com.au
www.moffat.com.au

New South Wales
Telephone 02-8833 4111
Email nswsales@moffat.com.au

South Australia
Telephone 03-9518 3888
Email vsales@moffat.com.au

Queensland
Telephone 07-3630 8600
Email qldsals@moffat.com.au

Western Australia
Telephone 08-9202 6820
Email bgarcia@moffat.com.au

New Zealand
Moffat Limited
Christchurch
Telephone 03-389 1007
Email sales@moffat.co.nz
www.moffat.co.nz

Auckland
Telephone 09-574 3150
Email sales@moffat.co.nz

