



PARAMOUNT

Prover

Bakery



Features & Benefits



- Easy to operate digital control panels
- Supplied as standard with an internal light
- 304 grade stainless steel construction internal & external
- Fitted with floor as standard
- Available in 1 & 2 rack sizes
- Accommodates racks 525mm x 750mm

PARAMOUNT Prover

TECHNICAL DATA

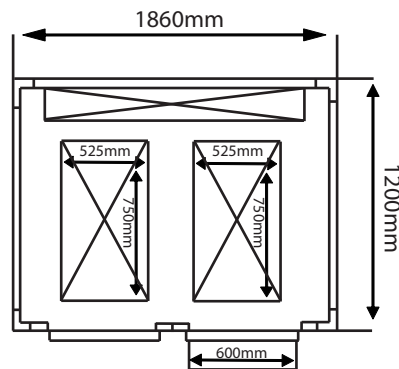
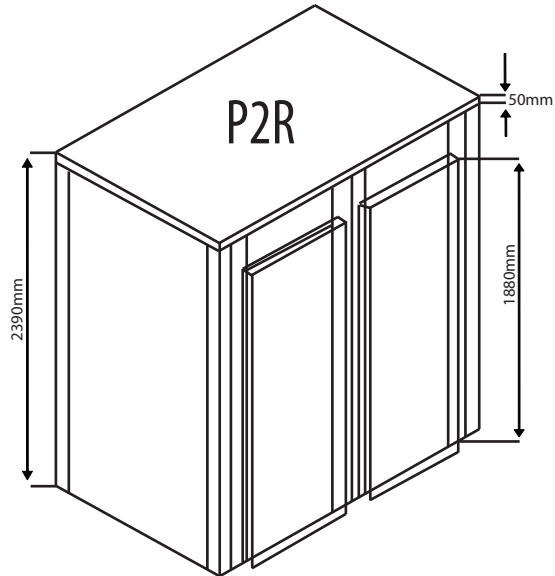
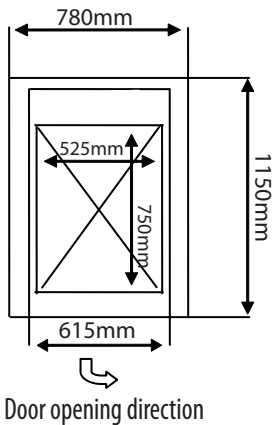
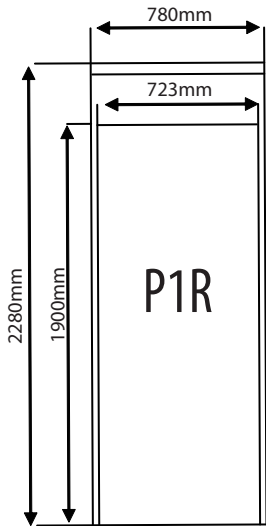

Digital Control Panel

MODEL	Dimensions	Power
P1R	780mm W x 1150mm D x 2280mm H	Single phase, 240V, 50Hz, 15 amp
P2R	1860mm W x 1200mm D x 2390mm H	Single phase, 240V, 50Hz, 15 amp

NOTE: Dimensions EXCLUDE all protrusions - door handles, drain exits etc.

PLEASE NOTE: Both units require the following:

- Drain Outlet
- 1/2" BSP Inlet

In line with policy to continually develop and improve its products, Moffat reserves the right to change specifications and design without notice.

National Sales Hotline
Toll Free 1800 023 953

Melbourne
740 Springvale Road
Mulgrave, Victoria 3170
Telephone (613) 9518 3888
Facsimile (613) 9518 3833
Email: vsales@moffat.com.au

Sydney
Telephone (612) 8833 4111
Facsimile (612) 8833 4122
Email: nswsales@moffat.com.au

Perth
Telephone (618) 9202 6820
Email: vsales@moffat.com.au

Adelaide
Telephone 1800 023 953
Facsimile (613) 9518 3833
Email: vsales@moffat.com.au

Brisbane
Telephone (617) 3630 8600
Facsimile (617) 3630 8623
Email: qldsales@moffat.com.au

Christchurch, New Zealand
Telephone (643) 389 1007
Facsimile (643) 389 1276
Email: sales@moffat.co.nz
Web: www.moffat.co.nz

Auckland, New Zealand
Telephone (649) 574 3150
Facsimile (649) 574 3159
Email: sales@moffat.co.nz
Web: www.moffat.co.nz

National 24 Hour Service Hotline
(Australia Wide)
Toll Free 1800 622 216

Replacement Parts
(Australia Wide)
Toll Free 1800 337 963

