

MSB125T | Zanotti SB Range Drop-In Refrigerated Chiller Systems

Refrigeration Systems

MSB125T

ZANOTTI SB RANGE DROP-IN REFRIGERATED CHILLER SYSTEMS

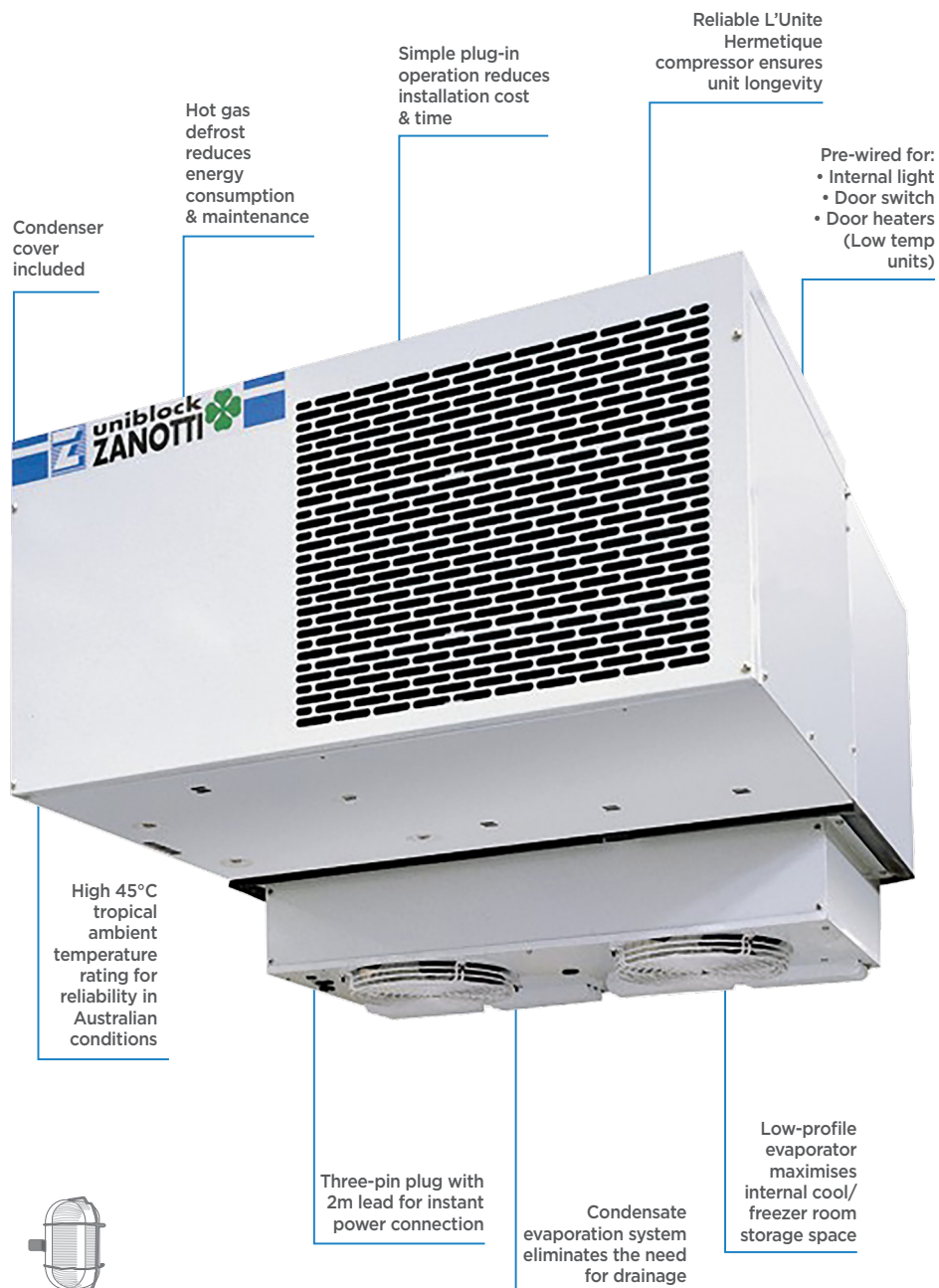

Advanced Digital Controller



Internal light included



Drainage may be required in extreme ambient conditions or when storing high-water content produce



MSB125T | Zanotti SB Range Drop-In Refrigerated Chiller Systems

Refrigeration Systems

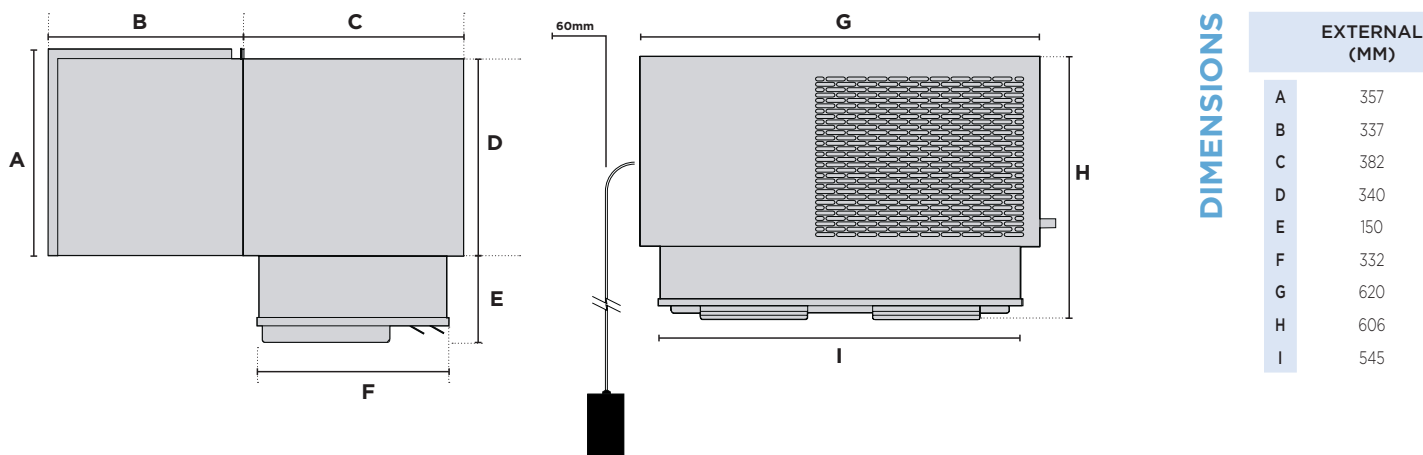

DIMENSIONS

EXTERNAL (MM)	
A	357
B	337
C	382
D	340
E	150
F	332
G	620
H	606
I	545

Mounting Scheme

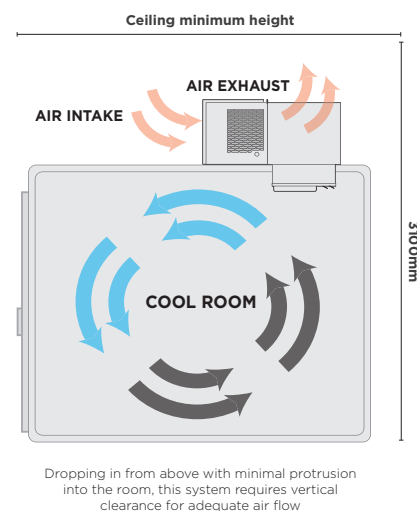
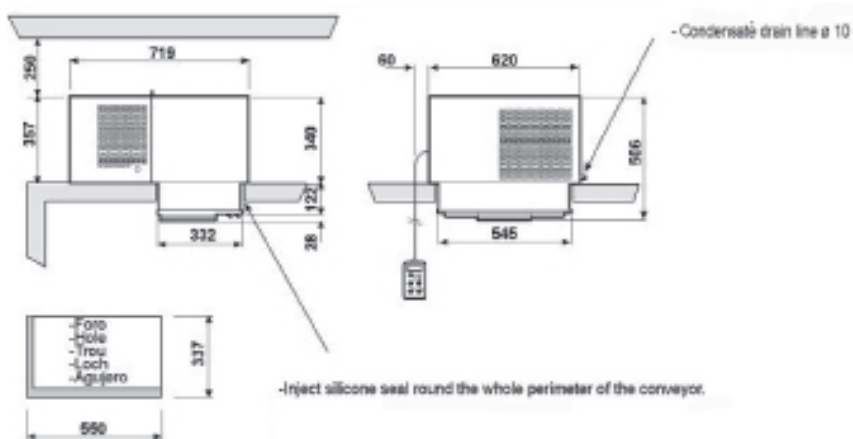

SPECIFICATIONS

Part Number	3835102
Refrigeration Capacity	1559W
Temp. Range (°C)	-5 to +10°C
Max. Ambient Temp. (°C)	45°C
Run/Full-Load (Amps)	5.2/7.3A
Temp. Display	Digital
Gross Weight (kg)	59kg
Refrigerant	R404a
Power Supply	15A
Defrost Type	Hot Gas
Type of Control	Electronic
Internal Light	Pre-Wired
Heated Door Trim	No
Drainage Required	No
Warranty	1 Year, Parts only
Warranty Service	Bromic Extra Care

* Medium temp rated at 5°C internal temperature and 30°C ambient temperature.

POWER DATA

Tc °C	Ta °C	P watt	P Kcal/h	V100 m³	V80 m³	V60 m³
20	1971	1695	17	15	14	14
25	1880	1617	15	14	12	12
10	30	1789	1539	14	13	12
35	1698	1460	13	12	11	11
40	1606	1381	12	11	10	10
20	1716	1476	13	12	11	11
25	1638	1409	12	11	10	10
5	30	1559	1341	11	10	9.1
35	1478	1271	10	9.1	8.3	8.3
40	1396	1201	9.4	8.6	7.8	7.8
20	1497	1287	11	10	9.1	9.1
25	1432	1232	9.9	9	8.2	8.2
0	30	1362	1171	9.1	8.3	7.6
35	1291	1110	8.2	7.5	6.8	6.8
40	1220	1049	7.4	6.7	6.1	6.1
20	1284	1104	8.3	7.6	6.9	6.9
25	1225	1054	7.6	6.9	6.3	6.3
-5	30	1162	999	6.9	6.3	5.7
35	1099	945	6.2	5.6	5.1	5.1
40	1035	890	5.5	5	4.6	4.6

BROMIC PTY Ltd reserve the right to alter specifications without notice.