

**MSB135T | Zanotti SB Range Drop-In Refrigerated Chiller Systems**

Refrigeration Systems

**MSB135T**

**ZANOTTI SB  
RANGE DROP-IN  
REFRIGERATED  
CHILLER  
SYSTEMS**



Advanced Digital Controller



Internal light included



Drainage may be required in extreme ambient conditions or when storing high-water content produce

## MSB135T | Zanotti SB Range Drop-In Refrigerated Chiller Systems

### Refrigeration Systems

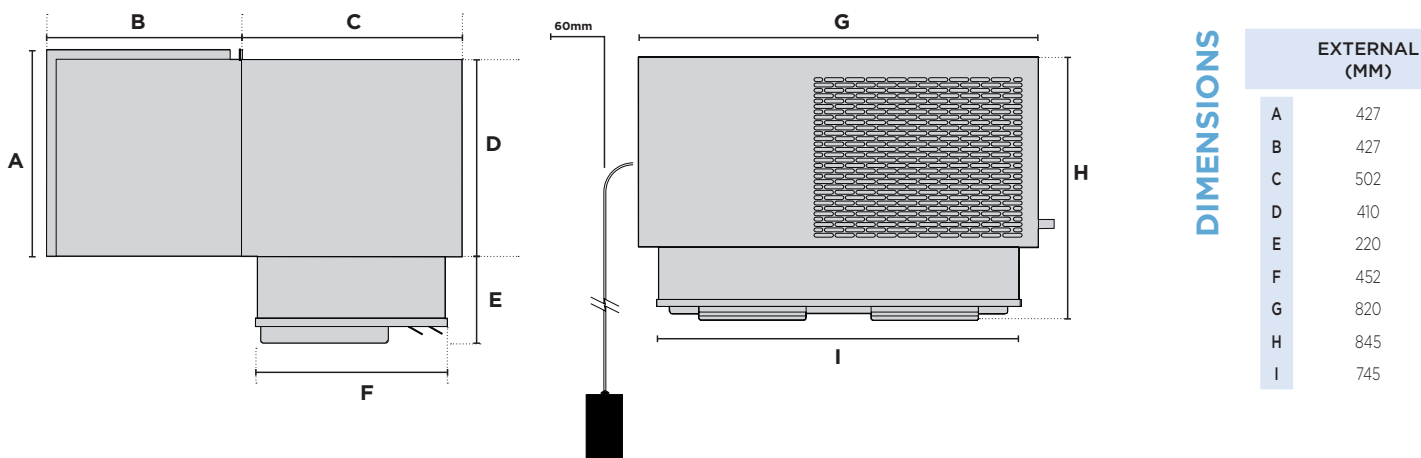

### Mounting Scheme

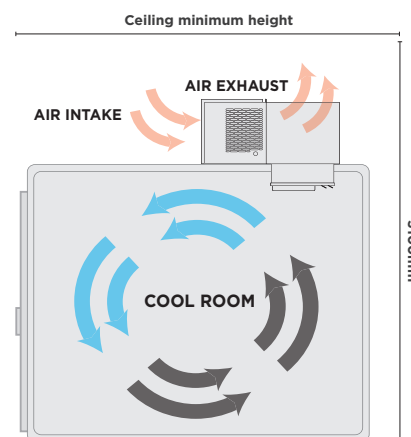
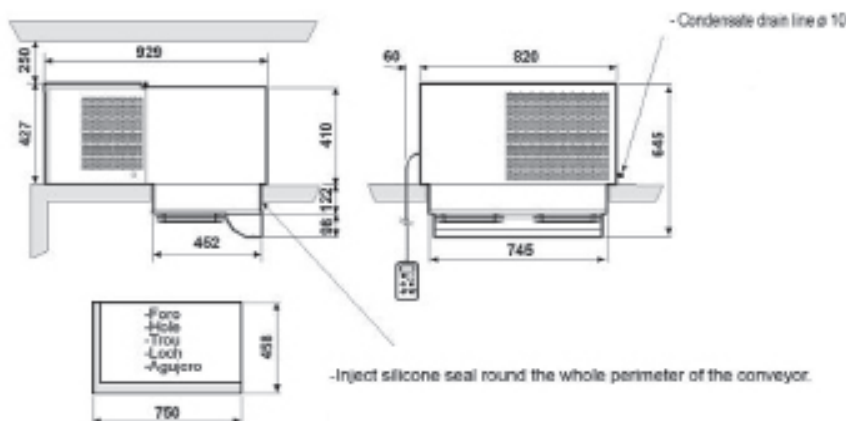

Dropping in from above with minimal protrusion into the room, this system requires vertical clearance for adequate air flow

### SPECIFICATIONS

Part Number	3835105
Refrigeration Capacity	4722W
Temp. Range (°C)	-5 to +10°C
Max. Ambient Temp. (°C)	45°C
Run/Full-Load (Amps)	12.2/21.4A
Temp. Display	Digital
Gross Weight (kg)	93kg
Refrigerant	R404a
Power Supply	25A
Defrost Type	Hot Gas
Type of Control	Electronic
Internal Light	Pre-Wired
Heated Door Trim	No
Drainage Required	No
Warranty	1 Year, Parts only
Warranty Service	Bromic Extra Care

\* Medium temp rated at 5°C internal temperature and 30°C ambient temperature.

### DIMENSIONS

Tc °C	Ta °C	P watt	P Kcal/h	V100 m³	V80 m³	V60 m³
	20	6131	5273	78	71	65
	25	5736	4933	71	65	59
10	30	5343	4595	65	59	54
	35	4950	4257	59	54	49
	40	4557	3919	52	47	43
	45	4164	3581	46	42	38
	20	5442	4680	67	61	56
	25	5082	4371	61	56	51
5	30	4722	4061	55	50	46
	35	4362	3751	49	45	41
	40	4002	3442	44	40	37
	45	3641	3131	38	35	32
	20	4789	4119	56	51	46
	25	4461	3836	51	46	42
0	30	4133	3554	46	42	38
	35	3804	3271	40	36	33
	40	3476	2989	35	32	29
	45	3148	2707	30	27	25
	20	4148	3567	46	42	38
	25	3853	3314	41	37	34
-5	30	3558	3060	37	34	31
	35	3264	2807	32	29	27
	40	2970	2554	27	25	22
	45	2677	2302	23	21	19