

Product Advantages:

- 5 levels GN1/1 with space of 71 mm.
- All stainless steel construction with radiuses inside for easy cleaning.
- The offset ventilation at the top allows for positioning up against a wall in optimum safety.
- Thermal insulation of muffle by glass wool.
- Removable protective plate for fan and heating element.
- Thermal and electric protection (IP 25) of the different internal components.
- Fan and heating cut out on opening of door.
- Time ranges from 0 to 90 minutes.
- Automatic start of reheating after selection via the timer knob.
- Buzzer at end of reheating cycle.
- Multi-program oven: Possibility of setting 2 to 3 different reheating times with buzzer between each program.
- Oven automatically switches to holding mode at the end of the reheating cycle(s).
- Stop of timer countdown on opening of door.
- Condensate drip tray, 40 mm deep on support GN1/1 (ref. 507 655).

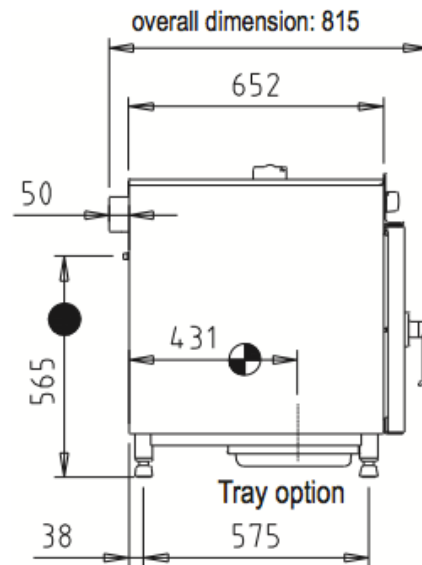
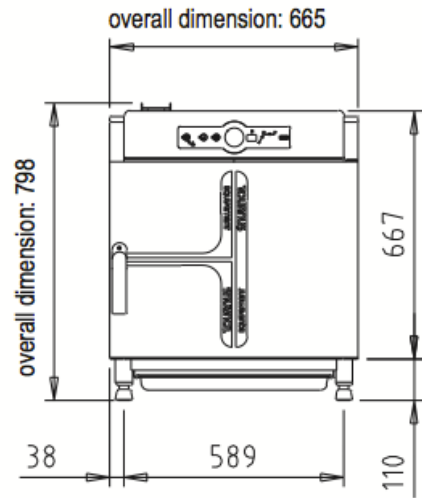

Technical Data:

Reference	507 624
Overall dim. (L x D x H)	665 x 815 x 798 mm
Maximum power rating	5410 W
Average power rating	1965 W
Power consumption	1.85 kWh
Connected load	3.3 kW – 15 A 240 1 phase AC – 50 Hz
Net weight (kg)	61
Number of portions	100 portions