

# MANISCOPIC

## ■ MT 625 T





### THE MANITOU POWER PACK

- Load capacity: 2500 kg
- Max. lifting height: 5.85 m
- Height: 1.92 m
- Width: 1.82 m
- 2 speed hydrostatic transmission

 **MANITOU**

## MT 625 T

 **Lifting capacity**..... 2500 kg  
at 500 mm from forks heels  
Tipping load at max reach ..... 1040 kg  
Break out force  
as per standard ISO 8313-1986 ..... 3427 daN

 **Lifting height**..... 5.85 m  
**Time:** laden/unladen (in s)  
Lifting ..... 8/8  
Lowering ..... 5.4/5.3  
Telescope  
Extension ..... 5.6/5.9  
Retraction ..... 4.3/4  
Time unladen (in s)  
Crowd ..... 3.5  
Dump ..... 3.6

 **Front/rear tyres**  
12-16.5 SKS CL TUBELESS

 **Forks (mm)**  
Length ..... 1200  
Width x thickness ..... 125 x 45

 **Oil immersed multidisc brake**

 **KUBOTA engine**  
**Type**..... V3307-DI-T-E3B  
Capacity..... 4 cylindres/3331 cm<sup>3</sup>  
Power (ISO/TR 14396)  
Turbo ..... 75 hp/55.4 kW  
Max. torque. (ISO/TR 14396) ... 265 Nm at 1400 tr/mn  
Injection ..... direct  
Cooling ..... water

 **Transmission**..... hydrostatic  
Gear reverser ..... electro - hydraulic  
Speed forward and reverse..... 2/2

 **Hydraulics**  
Gear pump ..... 87.9 l/mn at 235 bar  
Flow divider priority for steering

 **Capacities**  
Cooling system ..... 12 l.  
Transmission oil ..... 85 l.  
Engine oil ..... 11.2 l.  
Fuel tank ..... 63 l.

 **Empty weight (with forks)** ..... 4710 kg  
Overall **Width** ..... 1.82 m  
Overall **Height** ..... 1.92 m  
**Turning radius** (outer wheels) ..... 3.30 m  
**Length** at carriage ..... 3.90 m  
**Ground clearance** ..... 0.33 m  
**Drawbar pull** ..... 4170 daN

The indicated specifications are not binding on the maker and may be modified without notice.  
The Manitou trucks presented in this brochure may be fitted with optional items of equipment.

## Maximum height reach: 0.66 m

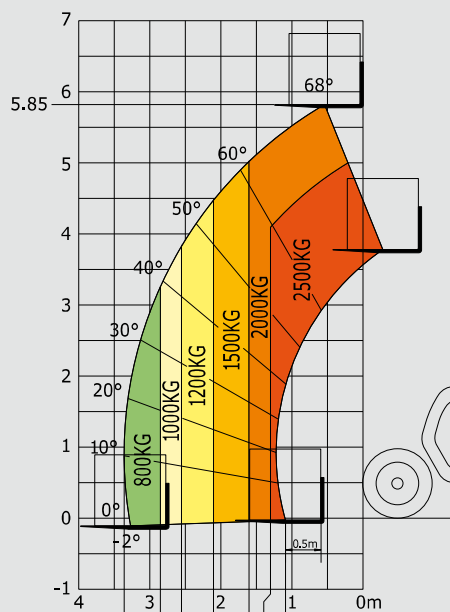

As per standard EN 1459 Annex B

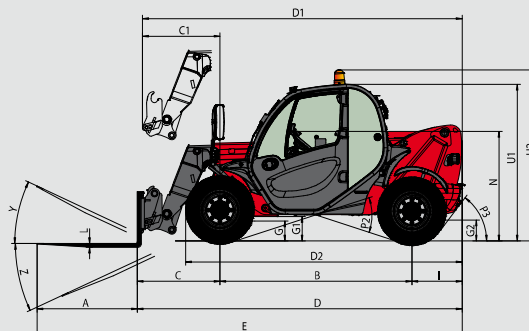

MT 625 T	
A	1200
B	2300
C	991
C1	928
D	3894
D1	3831
D2	3275
E	5094
F	1492
F1	1492
G	240
G1	330
G2	253
I	603
J	797
K	1015
L	45
N	1314
O	125
P2	37
P3	52
R	3150
S	6651.5
T	3935
U1	1920
U2	2054
V	4700
V1	765
V2	3310.5
W	1813
Y	11.8°
Z	116.5°

(mm)

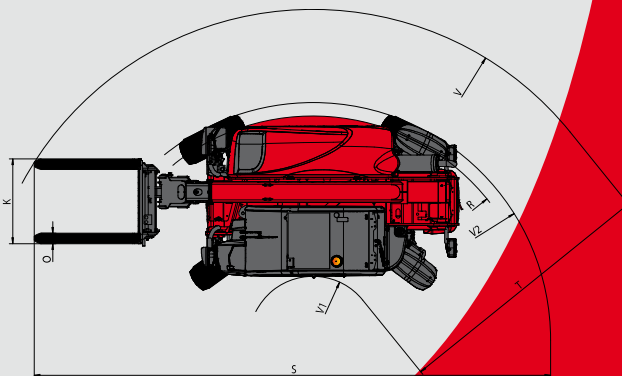
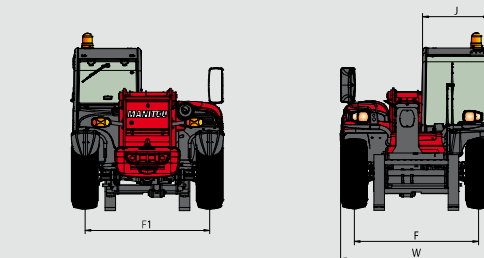

**MANITOU BF SA**  
B.P. 249 - 44158 Ancenis Cedex - France  
Tel. : 33 2 40 09 10 11 / Export Department Fax : 33 2 40 09 10 97  
www.manitou.com

700441EN\_A\_0210\_MT625T.indd - BE527 Indice C

