

HOBART701 S Ridge Avenue, Troy, OH 45374
1-888-4HOBART • www.hobartcorp.com**6430 • 6460
PEELER****6430 • 6460
PEELER****SAVE TIME
SAVE WORK
SAVE FOOD**

Two stainless steel vegetable peelers loaded with features that meet these important kitchen needs . . . speed, no flats or bruising, reduced waste, gentle action. In three minutes or less the Models 6430 and 6460 will peel a full load of potatoes, carrots or other root vegetables.

These peelers have a large disc made of durable reinforced plastic—not cast iron—with the abrasive permanently bonded to its surface. Bigger but lighter—actually weighs 48% less than the ordinary cast iron type. No struggling to remove this disc for cleaning.

Convenience features, such as built-in peel trap, lock-on hopper cover, adjustable legs, and centralized controls make these Hobart Peelers a must for modern kitchens. Hopper with abrasives permanently bonded to its interior surface, insures constant rotation of vegetables. All combine to let you tailor this peeler to your kitchen needs.

DISPOSER STAND with stainless steel legs and four bolt-down adjustable, leveling feet permit installation of food waste disposer for Hobart Models 6430 & 6460. Permits continuous drain disposal of all peelings. (Peelers with stand, with or without disposer, not submitted for UL listing.) Stand is furnished with solenoid water control valve and air-gap type inlet.

Hobart Model FD2-50 with long upper housing Disposer, in single phase voltages below 250V. Specifically designed for use with the 6430 and 6460 peelers. (See illustration at right.)

Specifications, Details and Dimensions on Inside and Back.



**Shown with
optional peel
strainer and trap.**

6430 • 6460 PEELER

HOBART

701 S Ridge Avenue, Troy, OH 45374
1-888-4HOBART • www.hobartcorp.com

DETAILS, DIMENSIONS AND CONNECTIONS PEELER WITH PEEL TRAP UNIT

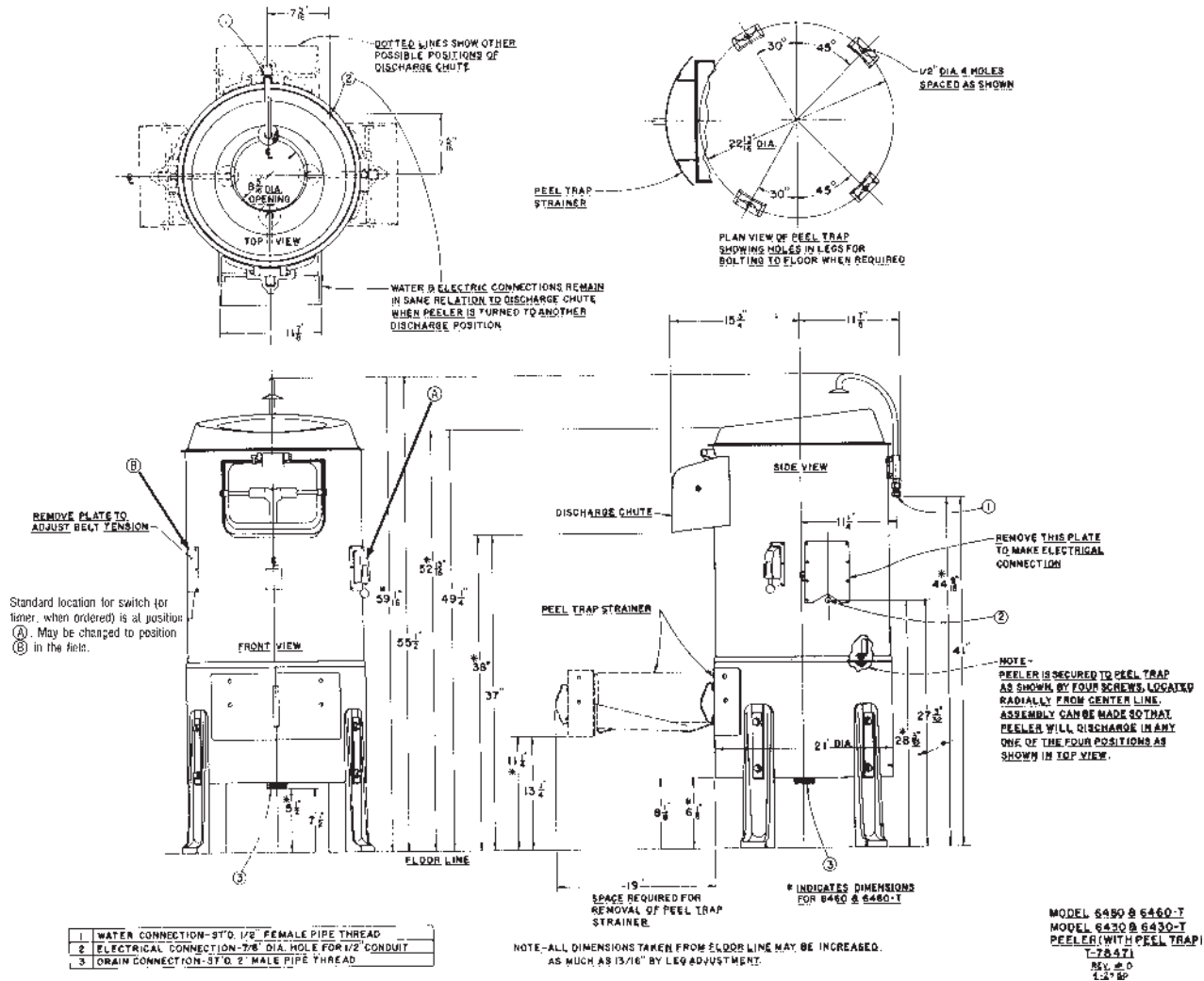

6430—Approx. Shipping Weight Peeler and Peel Trap Unit —201 lbs.
Approx. Shipping Weight Peeler less Peel Trap Unit —147 lbs.
Net Weight of Peeler and Peel Trap Unit —190 lbs.

6460—Approx. Shipping Weight Peeler and Peel Trap Unit —210 lbs.
Approx. Shipping Weight Peeler less Peel Trap Unit —156 lbs.
Net Weight of Peeler and Peel Trap Unit —198 lbs.



WARNING

ELECTRICAL AND GROUNDING CONNECTIONS MUST COMPLY WITH THE NATIONAL ELECTRICAL CODE AND/OR OTHER LOCAL ELECTRICAL CODES IN FORCE. PLUMBING CONNECTIONS MUST COMPLY WITH APPLICABLE SANITARY, SAFETY AND PLUMBING CODES IN FORCE.



701 S Ridge Avenue, Troy, OH 45374
1-888-4HOBART • www.hobartcorp.com

6430 • 6460
PEELER

**DETAILS, DIMENSIONS AND CONNECTIONS
OF PEELER WITH DISPOSER STAND**

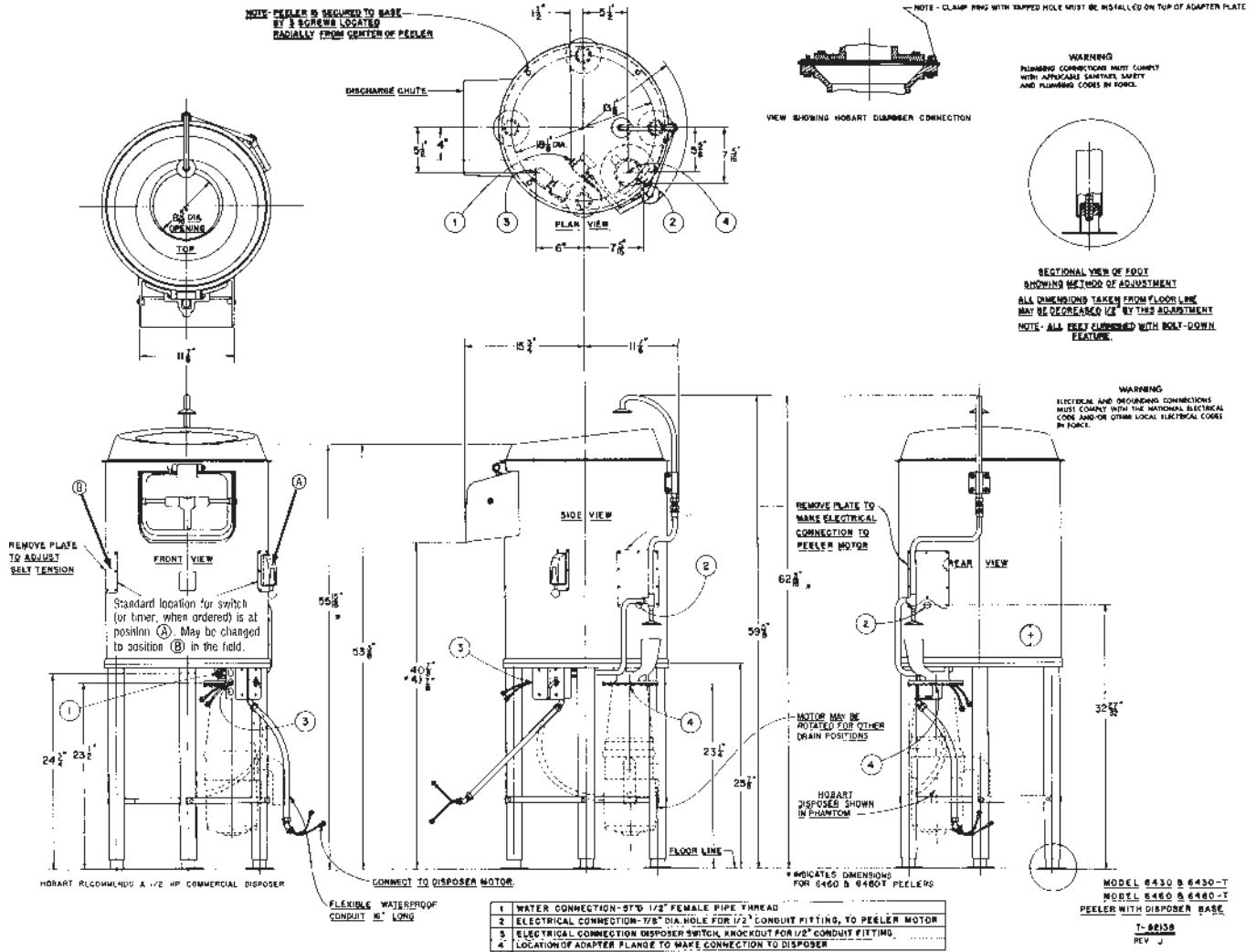

Single phase only.
DO NOT use three phase disposers.

- | | |
|---|-----------|
| 6430—Net Weight of Peeler | —142 lbs. |
| —Domestic Shipping Weight of Peeler | —147 lbs. |
| 6460—Net Weight of Peeler | —150 lbs. |
| —Domestic Shipping Weight of Peeler | —156 lbs. |
| 6430—Net Weight of Disposer Stand | —58 lbs. |
| —Domestic Shipping Weight of Disposer Stand | —65 lbs. |
| 6460—Net Weight of Disposer Stand | —60 lbs. |
| —Domestic Shipping Weight of Disposer Stand | —70 lbs. |

NOTE—Disposer Stand shipped in carton separate from Peeler

WARNING
ELECTRICAL AND GROUNDING CONNECTIONS MUST COMPLY WITH THE NATIONAL ELECTRICAL CODE AND/OR OTHER LOCAL ELECTRICAL CODES IN FORCE. PLUMBING CONNECTIONS MUST COMPLY WITH APPLICABLE SANITARY, SAFETY AND PLUMBING CODES IN FORCE.

6430 • 6460 PEELER

HOBART

701 S Ridge Avenue, Troy, OH 45374
1-888-4HOBART • www.hobartcorp.com

SPECIFICATIONS Listed by Underwriters Laboratories Inc and National Sanitation Foundation

MOTOR: ¼ H.P., Model 6430; 1 H.P. Model 6460. The motor features manual reset overload protection, grease-packed ball bearings, and ventilation within the peeler enclosure. Single phase is capacitor-start, induction run, and three phase is polyphase, squirrel-cage, induction-run type.

ELECTRICAL SPECIFICATIONS: 115/60/1, 200-230/60/1, 200-230/60/3, 460/60/3 UL Listed. 115/50/1, 220-240/50/1, 220-240/50/3, 380-415/50/3—Not submitted for UL Listing.

SWITCH: Manual tumbler type, located on right side of discharge chute as standard. Switch can be relocated to other side of chute if desired.

TIMER—Models 6430T and 6460T: Synchronous 4-minute timer, adjustable for any increments from ½ minute up to 4 minutes, with 15-second markings etched on a large timer dial. This timer is furnished only in single phase specifications as standard.

DRIVE: Multigrip, poly V-belt provides the direct speed reduction between motor and peeling disc. Belt adjustment may be accomplished from outside the machine. The stainless steel drive shaft is rigidly mounted on grease-packed ball bearings. Advanced designed triple protection sealing prevents entrance of water into shaft bearings.

PEELER UNIT: Cylindrical construction, heliarc-welded stainless steel with abrasive permanently bonded on interior surface of peeling hopper. A one piece, reinforced plastic molded, lightweight, easily removable, positive locking hopper cover is provided for easy cleaning. Quick-opening-removable aluminum hopper door and positive, cam-type pressure lock. Discharge chute is cast aluminum. To facilitate installation, the peeler unit can be positioned at 90° intervals, in relation to the peel trap unit.

ABRASIVE DISC: An extremely lightweight fiberglass reinforced plastic disc is 20½ inches in diameter. The silicon-carbide abrasive is permanently bonded to the disc, assuring unequalled long service. Disc can be easily and quickly removed for cleaning by removing the lightweight hopper cover. Two angle mounted wipers provide positive movement of waste into the outlet.

OPTIONAL EQUIPMENT:

PEEL TRAP UNIT: This unit consists of a base, strainer and legs.

BASE—Constructed with a closed top which prevents moisture from entering motor and drive unit. The sloping bottom insures the diversion of water into a two inch male drain pipe connection.

STRAINER—The standard strainer has a stainless steel front and stainless steel rectangular drawer. The bottom of the drawer is removable for easy cleaning.

LEGS—There are four adjustable cast aluminum legs. The working height of the machine is 37" from the floor to the bottom of the discharge chute. The legs can be adjusted 1/16" to compensate for floor variations.

WATER INLET: The inlet is the air-gap type, mounted at the rear of the peeler unit at sufficient height to meet plumbing codes. The water from the inlet impinges on the curved surface of the hopper cover to form a fan pattern of water into the unit. This design promotes interior self-cleaning and forms a water curtain which prevents undesirable splash.

WORKING CAPACITY: Model 6430 peels 30-33 pounds in one to three minutes. Model 6460 Peeler peels 50-60 pounds in similar time.

FINISH: Peeler and peel trap unit are #4 polished satin-finished stainless steel. Plastic molded hopper cover is gray. Door and handle, discharge chute, and legs are cast aluminum and ball bur-nished for durability. Bottom of peeler unit is cushioned in resilient rubber trim molding.

DETAILS, DIMENSIONS AND CONNECTIONS PEELER ONLY

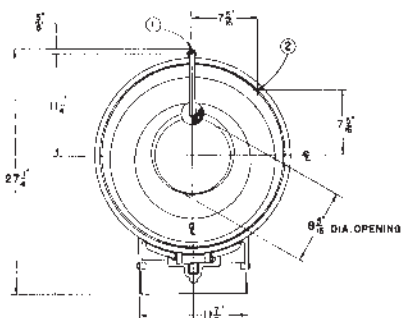

1	WATER CONNECTION-STD. 1/2" FEMALE PIPE T.H.D.
2	ELECTRICAL CONN.-7/8" DIA. HOLE (FOR 1/2" CONDUIT)
3	DRAIN HOSE-2-3/8" I.D. X 2-3/4" O.D.

WARNING

ELECTRICAL AND GROUNDING CONNECTIONS MUST COMPLY WITH THE NATIONAL ELECTRICAL CODE AND/OR OTHER LOCAL ELECTRICAL CODES IN FORCE. PLUMBING CONNECTIONS MUST COMPLY WITH APPLICABLE SANITARY, SAFETY AND PLUMBING CODES IN FORCE.

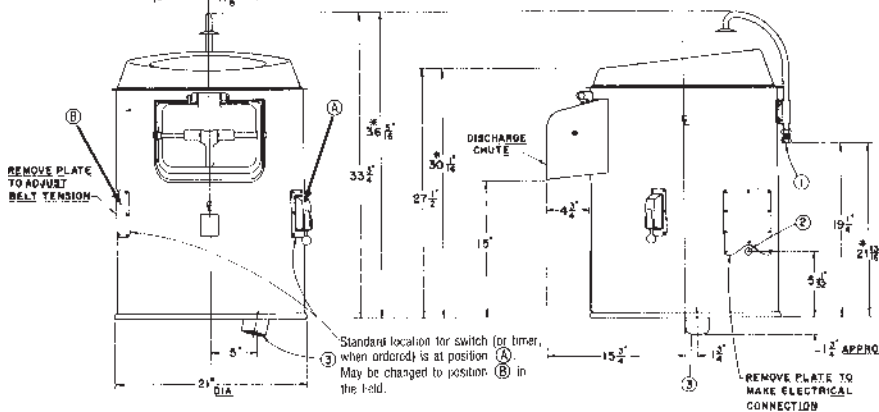

MODEL 6430 & 6430-T
MODEL 6460 & 6460-T
PEELER (WITHOUT TRAP)
8-78462
REV. C
2-17-80



701 S RIDGE AVENUE
TROY, OHIO 45374-0001

As continued product improvement is a policy of Hobart, specifications are subject to change without notice.