

Product Information:

- High performance undercounter dishwasher
- **E-Management:** intuitive and advanced electronic interface
- Four wash cycles 90/120/180 seconds, and 9 minute deep clean
- Green standby function that reduces energy consumption when idle
- Low water consumption of 2.0 litres per cycle, minimising water, energy and detergent use
- Partial double skin cabinet, and double skin door
- Pressed wash tank with rounded corners, for increased hygiene
- Upper and lower stainless steel wash and rinse arms
- Robust upper tank scrap filters in stainless steel
- Automatic drain pump with self-cleaning function
- Soft start wash pump
- Built in thermostop, ensures correct rinse temperatures
- Built in detergent and rinse-aid injection
- **18-months parts and labour warranty**

Included Accessories:

- 1 x flat cup basket 500x500mm
- 1 x peg plate basket 500x500mm
- 1 x cutlery insert
- 1 x water inlet hose, length 1.5m
- 1 x drain hose, length 2.0m
- Adjustable front feet and rear rollers

Optional Accessories:

- Stand with basket storage under
- Additional baskets

Specifications:

Model	AF50.35EM
W x D x H (mm)	572 x 658 x 814
Weight	53kg
Packed Dimensions (mm)	660 x 720 x 960
Packed Weight	61kg
Total Connected Load	3.25kW
Electrical Connection	230VAC / 50Hz (15A plug & lead fitted)
Water Quantity Per Cycle	2.0 Litres
Water Connection	1.5m Hose / 3/4" BSP
Water Inlet Pressure	200 - 500KPA
Tempered water supply	10°C - 60°C
Waste Connection	2m Hose / ø20.5mm

Legend:

- A Electrical Connection
- B Water Connection
- C Drain Connection
- D Detergent Line
- E Rinse-Aid Line

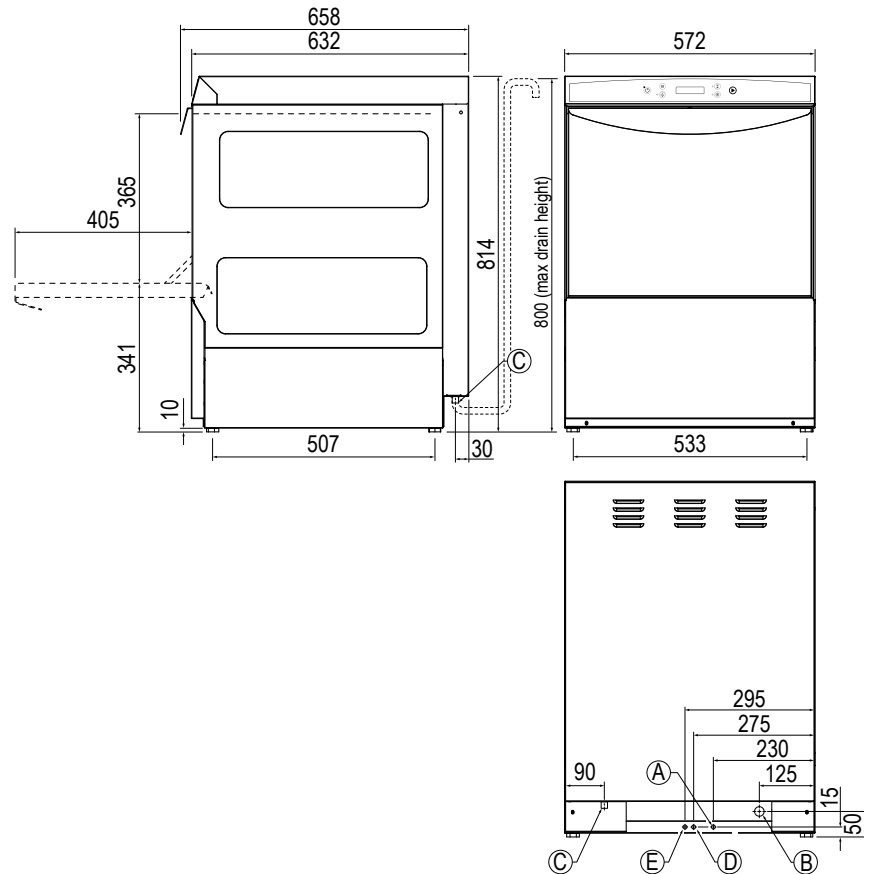

Due to continuous product research and development, the information contained herein is subject to change without notice.

Revision: A - 15/08/2024 - 04

