

ALTO SHAAM 1000-BQ2/192

HOT HOLDING BANQUET CARTS

Stainless steel exterior with dutch doors and transport handles. Cabinet is controlled with an ON/OFF power switch, adjustable electronic thermostat which includes a heat indicator light and temperature set knob. 4 x chrome plated wire shelves included.

A full-perimeter, wall-friendly bumper is included, along with casters.

Banquet cart will hold covered meals without plate carriers. Additional shelves equip cart to hold pre-plated meals without covers, trays, and bulk food items in pans.



STANDARD FEATURES

- HALO HEAT a controlled, uniform heat source that gently surrounds food for better appearance, taste, and longer holding life.
- Close temperature tolerance and even heat application provides even heat from top to bottom – side to side.
- Holds preplated food fresh, flavorful, and hot.
- No moisture pans, water or canned heat needed.
- Designed to adapt to any type of banquet holding:
 - Covered plates, stacked
 - Covered or uncovered plate carriers
 - Accepts trays for banquet service
 - Additional shelves for full-size and half-size pans (gastronorm pans)
- Dutch doors designed to keep heat in the top portion of the cabinet while removing plates from the bottom.
- Non-magnetic stainless steel interior resists corrosion.
- Full perimeter, wall-friendly bumper, transport handles, and heavy duty casters.

SPECIFICATIONS ARE SUBJECT TO CHANGE WITHOUT NOTICE.

From the world of Comcater!

National Head Office
156 Swann Drive
Derrimut VIC 3030
Tel: +61 3 8369 4600
Fax: +61 3 8369 4695

Melbourne
96-100 Tope Street,
South Melbourne VIC 3205
Tel: +61 3 8369 4600
Fax: +61 2 8699 1299

Sydney
20/4 Avenue of the Americas
Newington, NSW 2127
Tel: +61 2 9748 3000
Fax: +61 2 9 648 4762

Brisbane
1/62 Borthwick Avenue
Murarrie QLD 4172
Tel: +61 7 3399 3122
Fax: +61 7 3399 5311

ALTO SHAAM 1000-BQ2/192

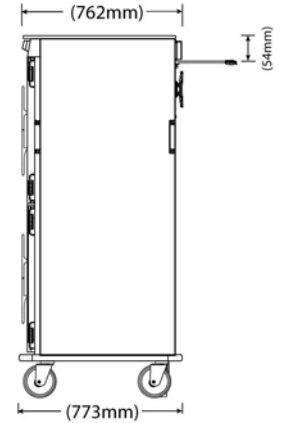
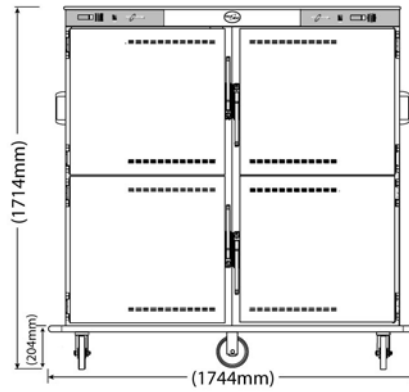
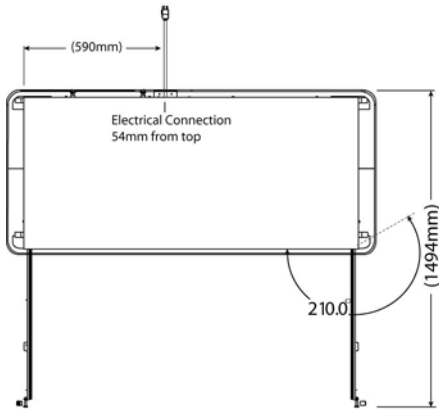

DIMENSIONS

External Dimension: 1714H x 1744W x 773D mm

Interior Dimension: 1346H x 718W x 648D mm

TECHNICAL DATA

Power Supply	10 amp single phase. 240 Volts
Voltage	240
Phase	1
Hertz	50
Amps	13
kW	3

SPECIFICATIONS ARE SUBJECT TO CHANGE WITHOUT NOTICE.



www.comcater.com.au

PROUDLY DISTRIBUTED BY: