

## ALTO SHAAM 750-TH/II

### LOW TEMPERATURE COOK AND HOLD OVEN

Single compartment oven with either manual or electronic controls. (750-TH/111 features a digital control that includes 8 programmable menu buttons)

Oven is equipped with side racks with pan positions spaced on 35mm centers, 2 x stainless steel wire shelves, stainless steel drip pan with drain and external drip tray and casters.



### STANDARD FEATURES

- HALO HEAT a controlled, uniform heat source that maintains close temperature tolerances throughout the cooking and holding function. Offers uniform and consistent cooking on a daily basis, low shrinkage of bulk or portion-cut protein items, higher food moisture content, and significantly longer holding life.
- Cooks, roasts, re-heats, and holds in the same cabinet with set-and-forget controls to provide a better distribution of work loads.
- Cooks by time and automatically converts from cook mode to hold mode.
- Oven hoods, outside venting, and fire extinguisher systems are not required (IN MOST AREAS).
- Stackable design for additional capacity.
- Antimicrobial handle retards the growth of illness-causing pathogens.

SPECIFICATIONS ARE SUBJECT TO CHANGE WITHOUT NOTICE.

*From the world of Comcater!*

**National Head Office**  
156 Swann Drive  
Derrimut VIC 3030  
Tel: +61 3 8369 4600  
Fax: +61 3 8369 4695

**Melbourne**  
96-100 Tope Street,  
South Melbourne VIC 3205  
Tel: +61 3 8369 4600  
Fax: +61 2 8699 1299

**Sydney**  
20/4 Avenue of the Americas  
Newington, NSW 2127  
Tel: +61 2 9748 3000  
Fax: +61 2 9 648 4762

**Brisbane**  
1/62 Borthwick Avenue  
Murarrie QLD 4172  
Tel: +61 7 3399 3122  
Fax: +61 7 3399 5311

# ALTO SHAAM 750-TH/II

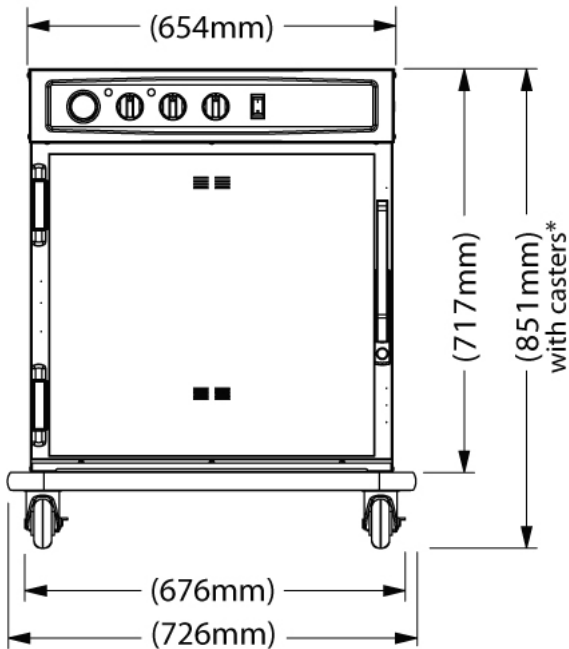

with optional bumper

- \*(807mm) - with optional casters
- \*(894mm) - with optional casters
- \*(874mm) - with optional legs

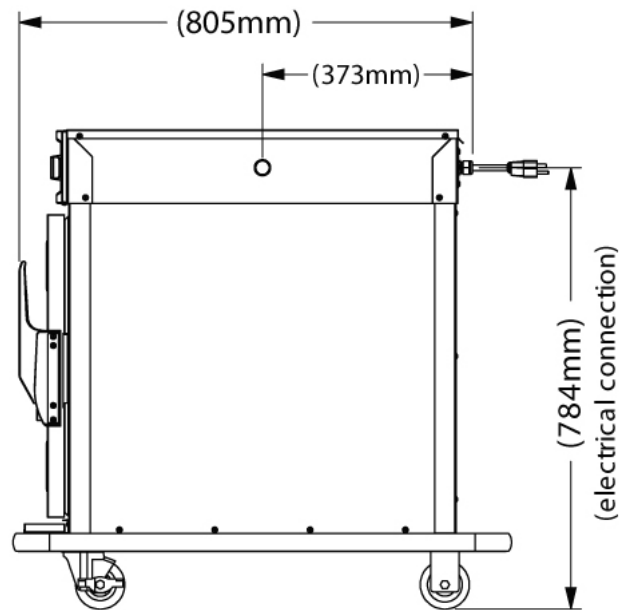

## DIMENSIONS

External Dimension: 851H x 676W x 805D mm

Internal Dimensions: 510H x 559W x 673D mm

## TECHNICAL DATA

Power Supply	15 amp single phase. 240 Volts
Voltage	240
Phase	1
Hertz	50
Amps	10.4
kW	2.4

SPECIFICATIONS ARE SUBJECT TO CHANGE WITHOUT NOTICE.



www.comcater.com.au

PROUDLY DISTRIBUTED BY: