

HOBART

WAREWASHING

HOOD-TYPE DISHWASHERS **AUP** | **AMX**



IT'S ALL ABOUT



**TOTAL PERFORMANCE
IN YOUR KITCHEN**

At HOBART, we take pride in providing reliable and innovative high quality kitchen equipment that has been engineered to ensure that whatever challenges the day may bring - you can make it happen with HOBART.

Let's make it happen!

EFFICIENCY.



HOBART
7 MARKETS
Countless challenges
1 SOLUTION

HOOD-TYPE DISHWASHERS **AUP** | **AMX**



HOSPITALITY

Bar & Pub / Bistro & Café /
Hotel & Restaurant



FOOD SERVICE

Hospital / Nursing Home /
Canteen / School & University



BAKERY

Bakery subsidiary / Production / Bakery industry



MEAT PRODUCTION

Butchery / Meat production industry



INDUSTRY



GLOBAL MARINE



AIRLINE CATERING





PROFI OR PREMAX IT'S YOUR CHOICE!

The **PROFI** line – everything a professional dishwasher needs. This successful product series from HOBART can be found wherever very high standards of cleanliness are required, tailored to the volumes to be washed and the degree of soiling of the wash ware. It combines efficient ware-washing with excellent user-friendliness and low operating costs. Numerous equipment options make the **PROFI** line a perfectly suited ware-washing solution for any operation.

The **PREMAX** line is the optimal choice for operators that need a higher level of proficiency with minimal operating costs and impressive user-friendliness, combined with outstanding performance. The **PREMAX** line is a highly economical and innovative dishwasher line on the market. In addition to the features of the **PROFI** models, **PREMAX** wins over users with its special product characteristics, proving to be an ideal partner for very high standards in warewashing.

PROFI LINE

PREMAX LINE

THE MODELS

WE HELP YOU WITH YOUR DECISION!

PROFI AMX

The **PROFI** model for reliable washing of glasses and dishes.



PROFI AMXXL

The extra-wide **PROFI** model for reliable washing of bakery baskets, butchery boxes, trays and gastronorm pans.



PROFI AMXT

The **PROFI** double rack machine for simultaneous washing of two racks.





THE MODELS

WE HELP YOU WITH YOUR DECISION!

PREMAX LINE EXCLUSIVE

PREMAX AUP

The premium model for very exacting standards when it comes to wash results and economy. ASR automatic soil removal makes it highly suited to very high utilisation rates and levels of soiling.



PREMAX AUPL

The extra-wide premium model for cleaning large-sized wash ware. ASR automatic soil removal makes it ideally suited to very dirty gastronorm pans, butchery boxes or utensils while delivering very high utilisation rates.



PREMAX AUPT

The double-capacity premium model for simultaneous washing of two racks. ASR automatic soil removal makes it great for white and black dishes. It can deliver very high utilisation rates and cope with high levels of dirt.





ASR AUTOMATIC SOIL REMOVAL

PREMAX LINE EXCLUSIVE

AUTOMATIC SOIL REMOVAL

Filter food waste and save resources

Thorough pre-washing by hand takes a lot of time and additional water but is unavoidable in everyday dishwashing. You can save yourself this step with the patented ASR soil removal. Plates can be placed directly in the rack without pre-rinsing – even if they are extremely dirty.

Our solution for you:

Automatic soil removal ASR. This function, which is exclusive to the **PREMAX** line, pumps all food waste straight out of the machine thereby preventing fine and coarse leftovers from clogging systems and contaminating the wash water. This reduces operating costs, protects the wash system and is environmentally friendly.

Your benefits at a glance

- Hygienically clean wash result
- Less water exchange during the course of the day
- Reduced costs for water, energy and cleaning agents
- Great machine protection
- The cleaning time remains the same

Reduced resource consumption

Save on water, energy and cleaning agent costs. How does it work? Very simple! Automatic removal of the food waste prevents fine and coarse debris from getting into the dishwasher and thus contaminating the wash water. Therefore, the wash tank does not need to be constantly emptied and filled with fresh water. Instead, the machine regenerates itself as required. This means you no longer need to change the water during a dishwashing shift.

Optimal machine protection

The daily routine in a kitchen is often characterised by time pressure and hectic rush. This can mean that food waste doesn't always get completely removed from plates. But this coarse debris often plugs the systems, preventing the machine from performing at full capacity.



Video of ASR

OUTSTANDING WASH RESULT

PREMAX LINE EXCLUSIVE

INTENSIVE PROGRAMME

Removes all soiling

Dried-on food residues stick stubbornly to your dishes? Not with the **PREMAX** hood-type dishwasher. We solve this problem with hot steam – impurities don't stand a chance.

How does that work?

- The structure of the encrusted dirt is broken up.
- The washing temperature is increased in a short time.
- The higher temperature improves the effectiveness of the detergent.

Even tiresome pre-soaking becomes a thing of the past. Knives, forks and spoons can be rinsed in the specially developed cutlery programme. The combination of high pressure and hot waste steam dissolves even stubborn food residue.

PREMAX LINE EXCLUSIVE

POWER-PLUS WASH PROGRAMME

High performance washing power against extreme soiling

For maximum performance, the switchable POWER-PLUS wash programme activates a second pump in addition to each existing washing pump.

- As a result, **PREMAX** AUP and AUPL have an increased wash performance of 1,000 l/min.
- The double-rack machine **PREMAX** AUPT even recirculates 2 x 1,000 l/min.

With this programme, even difficult-to-remove food residues are washed off – without the need for pre-cleaning. Yet the result is hygienically clean.

OUTSTANDING WASH RESULT

GENIUS-X² FINE FILTER SYSTEM

Constantly keeps the wash solution clean

The enhanced fine filter system cleans soiled water in just three steps, reducing detergent consumption.

The tank stays clean

Coarse soil and food waste are collected in the strainer basket, preventing them from reaching the tank.

Fine soil is removed

The collected fine soil is discharged from the machine after 10 seconds.

Washing does the rest

The residual fine soil is collected during washing and then pumped out.

Bonus benefit

During draining, the system cleans itself automatically, meaning manual cleaning is greatly reduced.

INTERLOCKED STRAINER

Checks whether tank cover strainer and fine filter are correctly inserted

If the strainer system is not in the proper position, the control displays a warning notice. The washing cycle can only be continued if the strainer is correctly positioned again.

For you this means

- The pump is protected against broken fragments and small cutlery.
- You benefit from a reduction in detergent consumption and operating costs.
- Soil is kept at bay.



STARCH-REMOVAL CLEANING PROGRAMME

Smooth, clean plates

Rice, potatoes and pasta contain starch and tend to leave visible traces on plates and bowls. Over time, the tableware not only feels rough, but also looks matte and unhygienic.

A new shine with HOBART

The special starch-removal cleaning programme ensures that your dishes feel completely smooth and clean again.

This provides you with the following benefits:

- Time-consuming manual handling of wash ware with aggressive cleaning solutions is eliminated.
- The starch-removal cleaning programme assists your staff and ensures shining wash ware.

ROTOR-X WASH SYSTEM

Special wash arms



The HOBART cross joint 4-spoke wash arms excel with their extensive wash performance.

- The wash arms double the contact time of the water with the wash ware.
- The washing action increases by 100 % compared to single-spoke wash arms.
- Wide-angle nozzles distribute the water optimally over the wash ware.

Your result

An optimal cleaning result over the entire surface.

The rotating ROTOR-X wash system consists of a top and a bottom cross joint wash arm. The **PREMAX** AUP model has two cross joint wash arms.

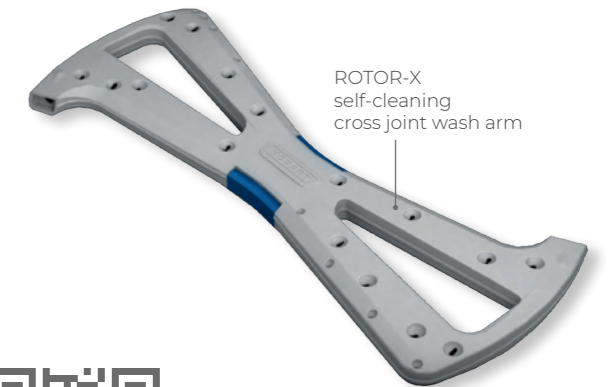

ROTOR-X self-cleaning cross joint wash arm



Video of wash arm



HIGH LEVEL OF ECONOMY

FULLY ENCLOSED HOOD

The clever way of minimising the amount of steam that escapes



Better indoor climate – as standard

Thanks to the fully enclosed hood, the hot waste steam remains in the system and is not released into the room. The indoor climate is thereby less contaminated and energy isn't lost.

Your benefits

- Noticeable improvement of indoor climate in the wash up area.
- Energy loss is reduced significantly.



Video of fully enclosed hood

HEAT- AND SOUND-INSULATED HOOD

Keep the heat in the machine

During operation, the heat is also retained in the system. The wash water does not cool off against the 15 mm thick walls of the hood. This increases the heat utilisation and helps to save energy.



EXHAUST HEAT RECOVERY VAPOSTOP ER

Good energy efficiency – lower operating costs



Thanks to the new VAPOSTOP ER function, HOBART's hood-type dishwashers provide an optimal solution for reducing energy consumption. The combination of a fully enclosed hood and heat exchanger achieve a high degree of efficiency. VAPOSTOP ER is integrated in the machine and prevents energy from being lost during and after the washing process because hot steam cannot escape. The energy is used to heat the incoming fresh water.

Your benefits:

- Reduction in total energy consumption of up to 10%.*
- Reduction of operation costs.
- No extra installation costs.
- No escaping steam when the hood is opened.
- Improved indoor climate - even with connection to hot water.

* Compared with a HOBART model with hood opening to the rear and without heat exchanger.



Video of exhaust heat recovery VAPOSTOP ER

DRAIN HEAT RECOVERY

Sophisticated use of waste water



The energy from the 60 °C hot waste water is used to heat up fresh water. And this is how it works: the drain heat recovery option directs the hot waste water along the fresh inflowing water. This heats the fresh water to 40 °C before it reaches its required final rinse temperature in the boiler.

Your benefits

- Saves up to 15 % of the total energy consumption of the machine.**
- Depending on usage, investment can be paid back in a very short period of time.
- Can also be used with demineralised water (osmosis water).

** Compared with a HOBART hood-type dishwasher without this option.



Video of drain heat recovery

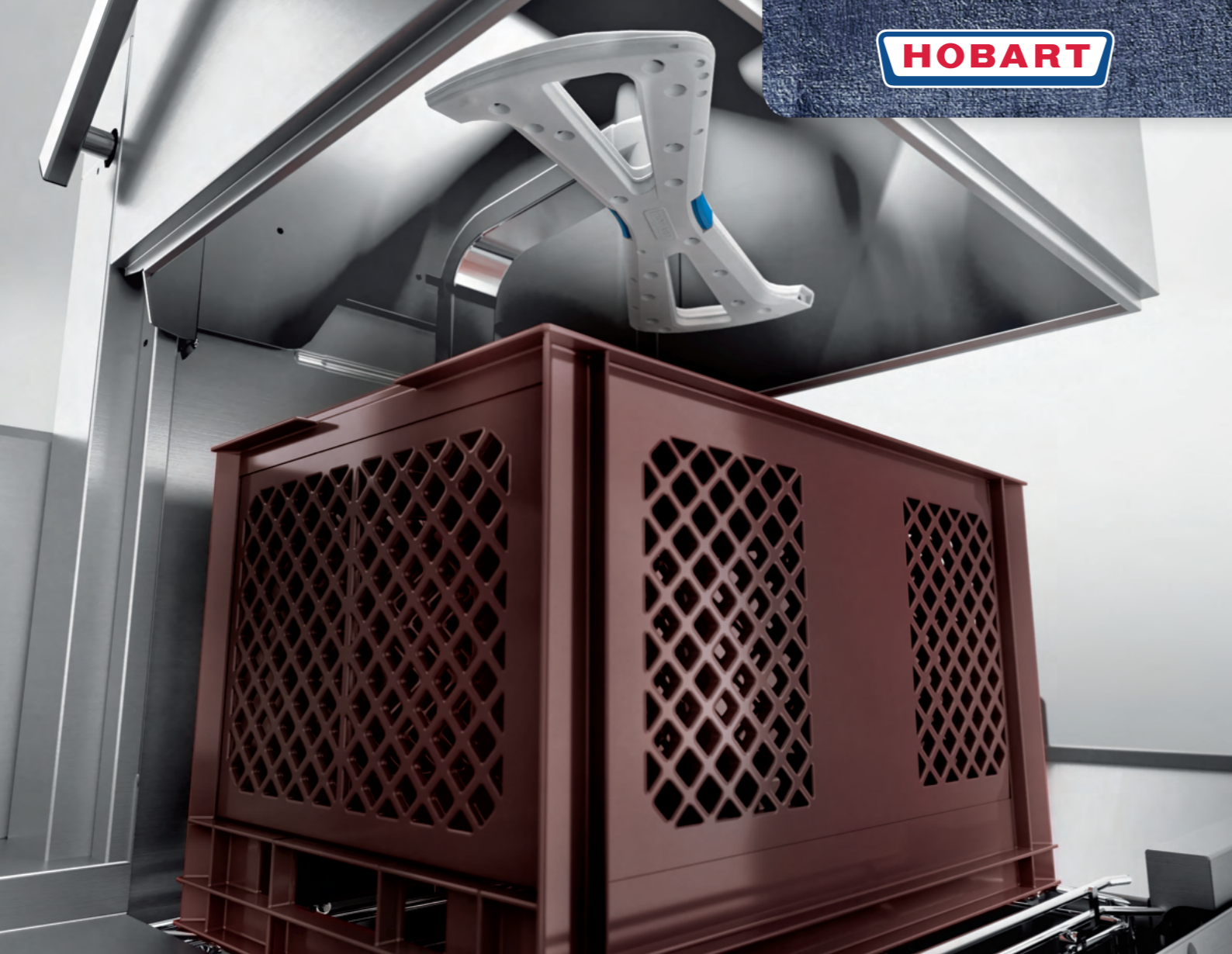

SENSO-ACTIVE RESOURCE MANAGEMENT

Responsible water consumption

The quality of the water is monitored constantly and water consumption is adapted accordingly. For low amounts of soil, the water consumption remains low; for higher levels of soil, it is increased.

Reduced operating costs

The innovative use of resources alone significantly reduces operating costs.

Your benefits

- Reliable wash results even with high levels of soil.
- Machine corrects operating errors.
- Consistent and sufficient regeneration of the wash solution with fresh water.
- Complete draining and refilling is no longer necessary.

INTELLIGENT ENERGY MANAGEMENT

Low connected load,
yet short heat-up times

To reduce the total connected load of dishwashers without intelligent energy management, the heating power in the heater is reduced.

We have the solution

Thanks to HOBART intelligent energy management, the heating unit is always filled at maximum boiler capacity. This reduces the filling time. During washing, booster loading can be reduced to the minimum required, which makes energy available for the wash pump and the tank heating.

Even with low total loading, short heat-up times are possible thanks to the intelligent use of the available energy.

HIGH LEVEL OF ECONOMY

PREMAX LINE EXCLUSIVE

ECO PROGRAMME

Great performance with low consumption

Low water consumption and short cycle times are important factors for reducing costs and saving time. This is why the HOBART **PREMAX** models work with waste steam, providing you with additional benefits:

- Excellent results are achieved with only 1.4 l of fresh water in the rinse.
- This reduces water and detergent consumption.

Shorter cycle times increase productivity

For the **PREMAX** hood-type dishwasher, the shortest cycle time is only 52 seconds. The capacity of the machine is increased by 17% to 70 racks/h.



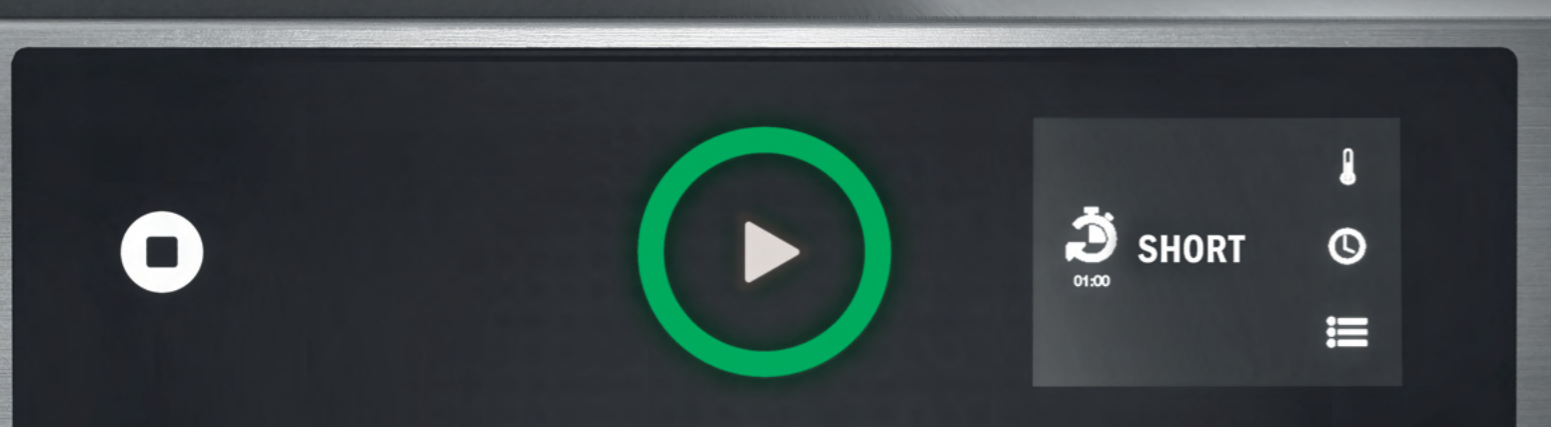

EASY HANDLING

VISIOTRONIC-TOUCH CONTROL

Simple handling for everyone

Single-button control in conjunction with a colour touch screen – it couldn't be easier. The VISIOTRONIC-TOUCH control simplifies use of your machine considerably and shows all the important information in the display using text and symbols.

Your benefits

- Easy selection of programmes.
- Easy settings.
- All important information is available at a glance.

REFILL SIGNAL FOR CHEMICAL CONTAINERS

Level control
Efficient and simple

The refill signal system uses optional suction lances to monitor the contents of external chemical containers. This ensures that you are provided with a timely notification of when detergent and rinse aid must be refilled, ensuring problem-free wash results.

REMAINING TIME INDICATOR

A constant overview of the wash cycle



The Visiotronic Touch control clearly displays programme progress.

- Blue: Programme just started
- Partly green: Machine is washing
- Green: Programme finished / machine ready to start
- Red: Error or notification



SELF-CLEANING WASH SYSTEM

No more clogged spray nozzles

The combined wash and rinse system features an innovative, patent-pending self-cleaning system for cleaning the wash arms during each wash cycle.



How does that work?

When the wash programme starts, the wash arm is flooded with wash solution. Within seconds, the soil is transported out of the wash arm using the incoming wash water. As the wash pressure rises, the balls on the inside of the wash arm are pressed against the wash valve and seal the valve. This ensures that the wash solution is distributed all over the dishes via the wash nozzles.

HYGIENE PROGRAMME

Eliminates germs and bacteria

Over time, limescale and soil particles can build up inside your machine. With the hygiene programme, limescale and bacteria do not stand a chance.

Alerts on the display tell you when you should next use the hygiene programme. After that, it's just a case of putting a hygiene tab into the machine and starting the programme. After just a short time, your utensil washer is hygienically clean again.

An overview of your benefits

- Fast removal of limescale deposits.
- Soil residue is cleaned from the machine.
- Provides a fresh smell.

CLIP-IN WASH AND RINSE SYSTEM

Make cleaning the machine as simple as possible

To make your work as easy as possible, both wash and rinse system can be removed and re-inserted using the CLIP-IN system in just one step.

To maintain the high performance and durability of your hood-type dishwasher, you should regularly clean various components. The parts are colour-coded to show you clearly which parts need be removed.



AUTOMATIC SELF-CLEANING PROGRAMME

Clean interior after every washing day

As the machine is drained, a multi-stage self-cleaning programme is run. Soil residues are dissolved using a regenerated wash solution and then rinsed out with fresh water.

An overview of your benefits

- Significantly reduced manual cleaning effort.
- Prevents dirt from building up on the machine interior.
- Cares for and protects your machine.

EASY HANDLING



BLOCKED FILTER SENSOR

Rinse with foresight

Strainers quickly become clogged in the presence of heavy soiling. For the dishwasher to perform at full capacity, the strainers must be cleaned regularly. But when is the right time?

The intelligent blocked filter sensor detects when the strainers need to be cleaned and lets you know with a warning on the control display.

HOOD LIFT

Simple use via one push of a button

User-friendly and energy-saving: with the optional HOBART hood lift, you can close your hood-type dishwasher with the push of a button. After the wash process, the hood opens automatically.

INTEGRATED WATER SOFTENER

Protects against calcification and extends service life

The water softening system, integrated as an option, removes minerals from the water that can cause hardness. This prevents limescale deposits that can lead to increased cycle times, burnt-out heating elements and unsatisfactory wash results.

USB INTERFACE

For simple data documentation

Temperature, fault messages and the selected programmes must be permanently documented for monitoring purposes. The VISIOTRONIC-TOUCH control automatically carries out this time-intensive task.

Convenient exporting of operational and consumption data

The HOBART hood-type dishwasher has a USB interface for the simple downloading of operational and hygiene parameters. This enables you to save all the relevant data on an external storage device.

RELIABILITY & FLEXIBILITY

INSTALLATION OPTIONS

For easy integration into the kitchen

Hood-type dishwashers from HOBART can be installed anywhere in the kitchen and adapted to suit the workflow. The hood-type dishwashers can also be loaded with racks from both the front as well as from the left or the right. As well as installation along a wall between the loading and unloading tables, all hood-type dishwashers can be integrated into a table system as corner installations.



DOUBLE CAPACITY

For large washing volumes

Get two for one: with the **PREMAX** AUP and **PROFI** AMXT models, two racks of dishes, serving trays, compact trays and black dishes can be washed simultaneously. This avoids unnecessary waiting periods and increases your capacity.

XL WASH CHAMBER

More space for increased performance

Display trays, baking trays, EN containers or larger plates: with the **PROFI** AMXXL and **PREMAX** AUPL you can wash large items effortlessly. The larger XL wash chamber provides space for wash ware up to 600 x 400 mm, such as trays, baking trays and EN containers.



SMARTCONNECT



HOBART SMARTCONNECT APP

Key features at a glance

The HOBART SmartConnect app provides you with a comprehensive overview of the status of your dishwasher – free of charge for 5 years.

Connect, learn, benefit

Based on this data, you can avoid downtime and contact HOBART customer service or an approved service partner. SmartConnect also provides illustrated instructions for smaller malfunctions so that you can rectify them yourself.

An overview of all functions

- Machine status (keep up-to-date with regard to the statuses of all your machines)
- Machine information (with all important settings and machine information)
- Recording of error codes (in addition, you will be notified by email of any system errors)
- Operating costs calculator (overview of the consumption costs)
- Hygiene information (as a log book)
- Machine operation (information about the efficient use of the machine)
- Settings for certain machine parameters can be configured via the app

You can find more information on the availability of SmartConnect in different countries and languages as well as further information at www.HobartSmartConnect.com

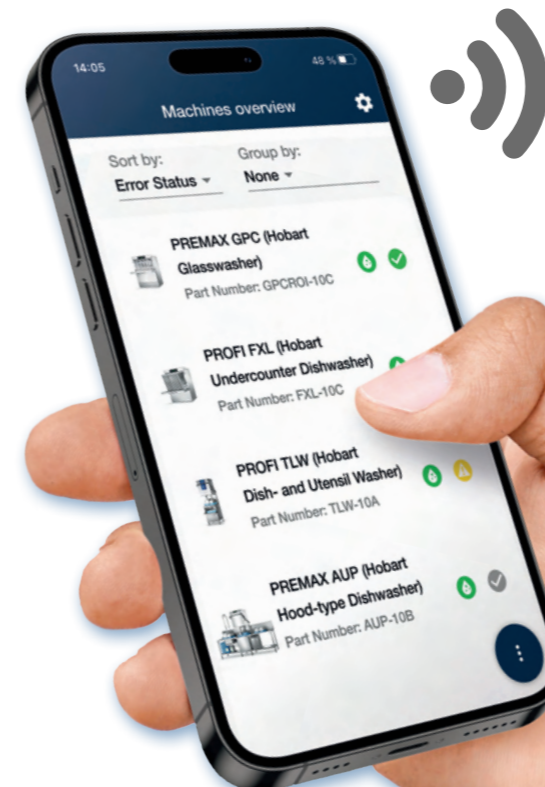

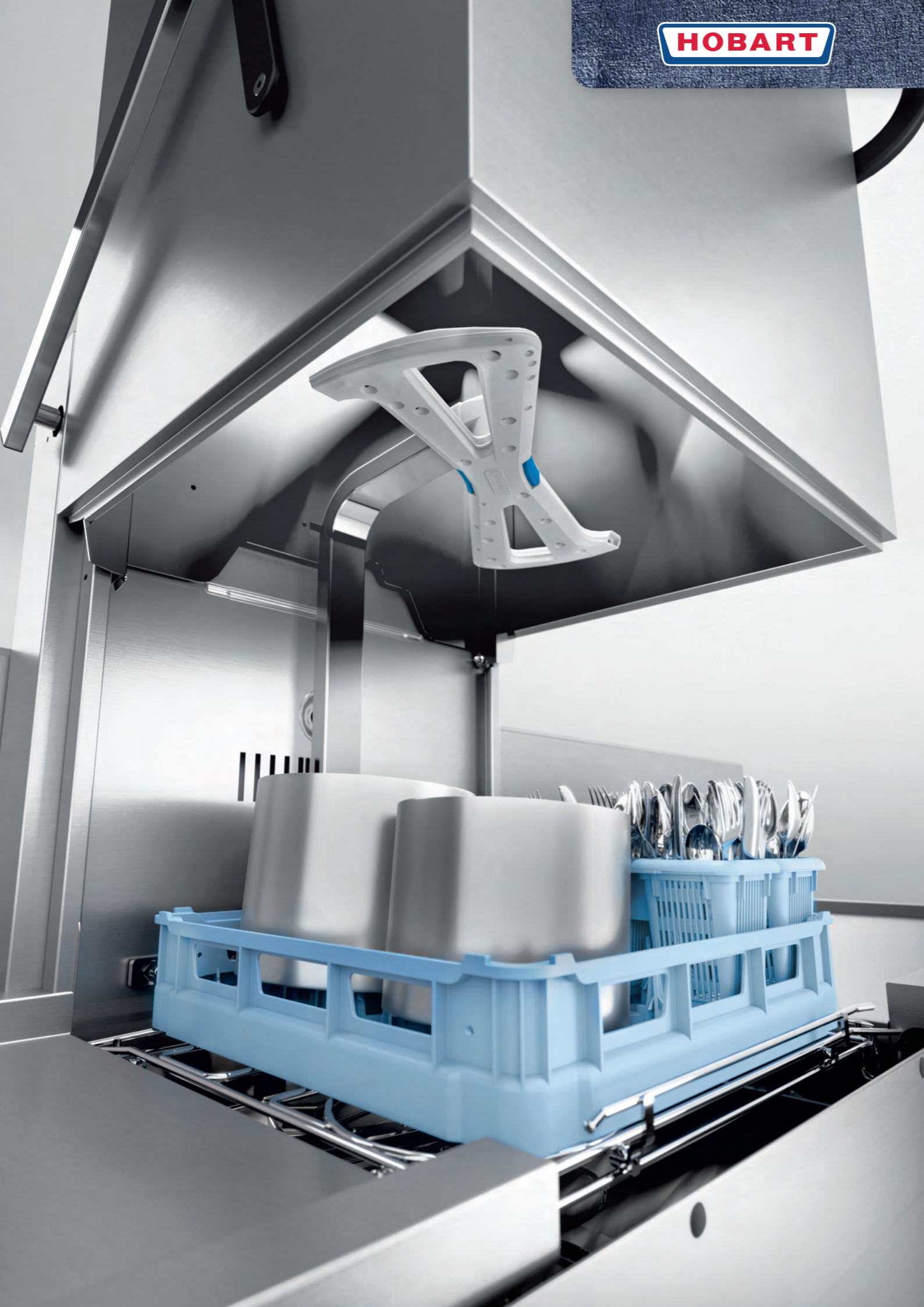

DRAWINGS

AMX

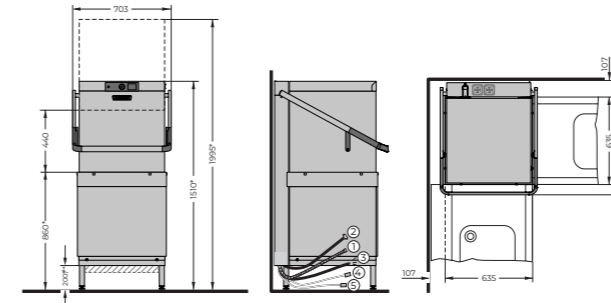

AUP

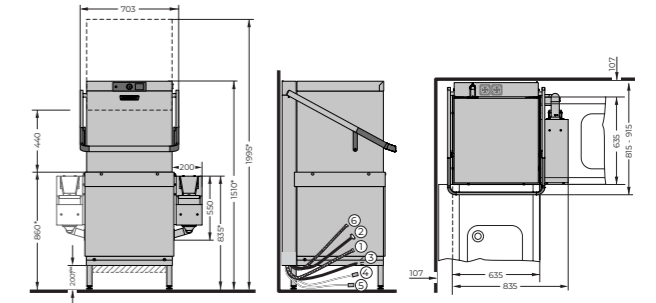

AMXXL

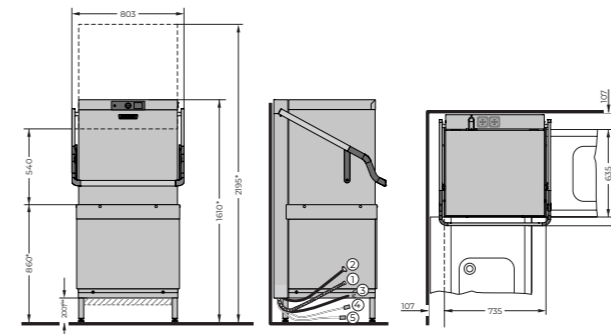

AUPL

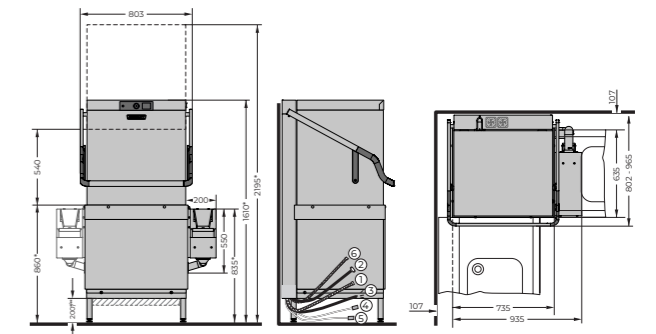

AMXT

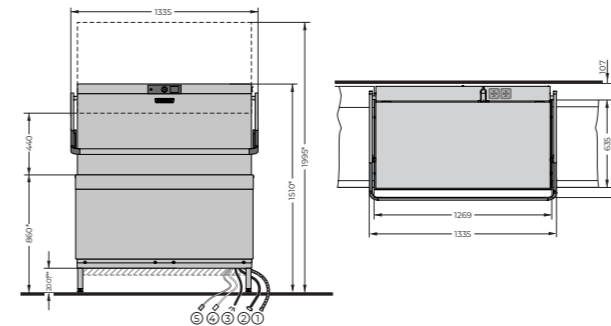

AUPT

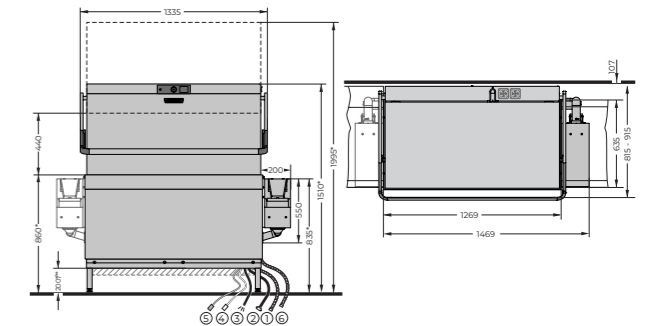

* +/- 25 mm foot adjustment
 ** 151 mm with optional drain heat recovery

 Optional exhaust heat recovery VAPOSTOP ER

- (1) Drain hose
- (2) Fresh water connection
- (3) Connection cable
- (4) Liquid detergent
- (5) Rinse aid
- (6) Drain hose ASR

FEATURES

MODELS	PROFI LINE		
	AMX	AMXXL	AMXT
ASR automatic soil removal	–	–	–
OUTSTANDING WASH RESULT			
Intensive programme with steam	–	–	–
POWER-PLUS wash programme	–	–	–
GENIUS-X ² fine filter system	●	●	●
Interlocked strainer	●	●	●
Starch-removal cleaning programme	●	●	●
ROTOR-X wash system	–	●	–
HIGH LEVEL OF ECONOMY			
Heat- and soundproof hood	●	●	●
Fully enclosed hood	●	●	●
VAPOSTOP ER exhaust heat recovery	○	○	○
Drain heat recovery	○	○	○
ECO programme	–	–	–
SENSO-ACTIVE resource management	●	●	●
Intelligent energy management	–	●	–
EASY HANDLING			
Integrated WiFi module*	●	●	●
SmartConnect app**	●	●	●
VISIOTRONIC-TOUCH control	●	●	●
Remaining time indicator	●	●	●
Refill signal for chemical containers	○	○	○
Self-cleaning wash system	●	●	●
CLIP-IN wash and rinse system	●	●	●
Hygiene programme	●	●	●
Automatic self-cleaning programme	●	●	●
Blocked filter sensor	–	●	●
Integrated water softener	○	○	–
Hood lift***	○	○	○
USB interface	●	●	●
FLEXIBILITY			
XL wash chamber	–	●	–
Double capacity	–	–	●
Installation options	●	●	●

MODELS	PREMAX LINE		
	AUP	AUPL	AUPT
ASR automatic soil removal	● PREMAX LINE EXCLUSIVE	● PREMAX LINE EXCLUSIVE	● PREMAX LINE EXCLUSIVE
OUTSTANDING WASH RESULT			
Intensive programme with steam	● PREMAX LINE EXCLUSIVE	● PREMAX LINE EXCLUSIVE	● PREMAX LINE EXCLUSIVE
POWER-PLUS wash programme	● PREMAX LINE EXCLUSIVE	● PREMAX LINE EXCLUSIVE	● PREMAX LINE EXCLUSIVE
GENIUS-X ² fine filter system	●	●	●
Interlocked strainer	●	●	●
Starch-removal cleaning programme	●	●	●
ROTOR-X wash system	●	●	●
HIGH LEVEL OF ECONOMY			
Heat- and soundproof hood	●	●	●
Fully enclosed hood	●	●	●
VAPOSTOP ER exhaust heat recovery	○	○	○
Drain heat recovery	○	○	○
ECO programme	● PREMAX LINE EXCLUSIVE	● PREMAX LINE EXCLUSIVE	● PREMAX LINE EXCLUSIVE
SENSO-ACTIVE resource management	●	●	●
Intelligent energy management	●	●	●
EASY HANDLING			
Integrated WiFi module*	●	●	●
SmartConnect app**	●	●	●
VISIOTRONIC-TOUCH control	●	●	●
Remaining time indicator	●	●	●
Refill signal for chemical containers	○	○	○
Self-cleaning wash system	●	●	●
CLIP-IN wash and rinse system	●	●	●
Hygiene programme	●	●	●
Automatic self-cleaning programme	●	●	●
Blocked filter sensor	●	●	●
Integrated water softener	○	○	–
Hood lift***	○	○	○
USB interface	●	●	●
FLEXIBILITY			
XL wash chamber	–	●	–
Double capacity	–	–	●
Installation options	●	●	●

● Inclusive ○ Optional – Not available

* You can find more information on the availability of SmartConnect in different countries and languages as well as further information at www.HobartSmartConnect.com.

** Free use for 5 years.

*** Automatic hood lift not possible for corner installations of **PREMAX AUP/AUPL**.

TECHNICAL DATA

MODELS	PROFI LINE		
	AMX	AMXXL	AMXT
CYCLE TIMES*	60 / 90 / 180 sec. and special programmes	52 / 75 / 180 sec. and special programmes	60 / 90 / 180 sec. and special programmes
CAPACITY			
Racks	60 /h	70 /h	120 /h
Plates	1,080 /h	1,680 /h	2,160 /h
Glasses	2,160 /h	2,520 /h	4,320 /h
TANK CAPACITY	23 l	40 l	40 l
WATER CONSUMPTION	1.8 l/rack**	1.8 l/rack**	1.8 l/rack**
PUMP OUTPUT	0.7 kW	1.2 kW	2 x 0.7 kW
Tank heating	2.5 kW	2.5 kW	3.3 kW
BOOSTER LOADING			
Standard	6.1 kW	12.2 kW / 6.1 kW with drain heat recovery	12.2 kW
Alternative	–	6.1 kW	6.1 kW
TOTAL LOADING			
Standard	6.9 kW 3 x 15 A	15.9 kW 3 x 32 A / 7.3 kW 3 x 15 A with drain heat recovery	16.5 kW 3 x 32 A
Alternative	–	9.7 kW 3 x 25 A	10.4 kW 3 x 20 A
Power supply	400 / 50 / 3N	400 / 50 / 3N	400 / 50 / 3N
DIMENSIONS			
Width	635 mm	735 mm	1,269 mm
Depth	742 mm	742 mm	742 mm
Height	1,510 mm	1,610 mm	1,510 mm
Loading height	440 mm	540 mm	440 mm
Height with open hood	1,995 mm	2,195 mm	1,995 mm
Rack size	500 x 500 mm	500 x 500 600 x 500 mm	500 x 500 mm

* The machine is equipped with an automatic cycle-time control which ensures hygienic rinse temperatures, even on a cold-water supply or with reduced heating performance.

** Water consumption may vary depending on the level of soiling and programme.

MODELS	PREMAX LINE		
	AUP	AUPL	AUPT
CYCLE TIMES*	52 / 70 / 170 / 180 sec. and special programmes	52 / 70 / 170 / 180 sec. and special programmes	52 / 70 / 170 / 180 sec. and special programmes
CAPACITY			
Racks	70 /h	70 /h	140 /h
Plates	1,260 /h	1,680 /h	2,520 /h
Glasses	2,520 /h	2,520 /h	5,040 /h
TANK CAPACITY	40 l	40 l	80 l
WATER CONSUMPTION	1.4 l/rack**	1.4 l/rack**	1.4 l/rack**
PUMP OUTPUT	1 x 1.2 kW + 1 x 0.7 kW	1 x 1.2 kW + 1 x 0.7 kW	2 x 1.2 kW + 2 x 0.7 kW
Tank heating	2.5 kW	2.5 kW	6.0 kW
BOOSTER LOADING			
Standard	12.2 kW	12.2 kW	12.2 kW
Alternative	6.1 kW	6.1 kW	6.1 kW
TOTAL LOADING			
Standard	16.6 kW 3 x 35 A	16.6 kW 3 x 35 A	21.9 kW 3 x 35 A
Alternative	10.5 kW 3 x 25 A	10.5 kW 3 x 25 A	18.5 kW 3 x 32 A
Power supply	400 / 50 / 3N	400 / 50 / 3N	400 / 50 / 3N
DIMENSIONS			
Width	635 mm	735 mm	1,269 mm
Depth	742 mm	742 mm	742 mm
Height	1,510 mm	1,610 mm	1,510 mm
Loading height	440 mm	540 mm	440 mm
Height with open hood	1,995 mm	2,195 mm	1,995 mm
Rack size	500 x 500 mm	500 x 500 600 x 500 mm	500 x 500 mm

CONCEPT SOLUTIONS for excellent wash result

WATER TREATMENT

The right solution for every water quality: softening systems to prevent the build-up of limescale and osmosis systems for a stainless wash result.

WASHING CHEMICALS

The right detergent for every application – perfectly suited to the individual machine. The HYLINE hygienic range.





MADE IN GERMANY

We provide this promise of quality to our customers, and it represents our personal standard upheld by all our staff at HOBART.



OUR VISION

Wash without water

Intensive market research has shown that our customers expect warewashing technology that combines efficiency with optimal performance. We are focused on meeting these demands and they form the foundation of our vision to "wash without water". This vision is our continuous incentive to break new ground in order to constantly reduce the consumption of water, energy and chemicals. We continue pursuing this goal methodically and with innovative solutions.

THE COMPANY

We are HOBART

HOBART is one of the world's leading manufacturers of commercial warewashing technology and a well known supplier of cooking, food preparation, and environmental technology. Established in 1897 in Troy, Ohio, today HOBART employs more than 6,900 employees around the world. At our manufacturing plant in Offenburg, Germany, HOBART develops, produces, and distributes warewashing technology worldwide. The hotel and catering trade, cafeterias, bakeries and butcher shops, supermarkets, airlines, cruise ships, automotive suppliers, research centres and pharmaceutical companies all over the world swear by our innovative products, which have proven their reliability for over 125 years.

OUR FOCUS

Innovative – economical – sustainable

This is our philosophy. With customer benefits always in focus, we continuously improve our products. Our group's Technological Centre, and our own Innovation Centre for Warewashing Technology at our headquarters in Germany, make this possible. Here, our innovative powers are combined to create products offering genuine added value for our customers. For us, being economical means delivering low operating costs and consuming few resources. For us, being sustainable means responsible handling of resources and a sustainable energy policy. This applies not only to the product in use, but in general to all areas of the organisation, such as purchasing or manufacturing.

HOBART SERVICE

Competent – fast – reliable

HOBART offers a worldwide service partner network for all products. These technicians always carry out maintenance and repair work competently, quickly and reliably. Thanks to regular trainings and many years of experience, they have detailed product knowledge and can help you focus on your business.

HOBART

DEUTSCHLAND/ÖSTERREICH

HOBART GMBH

Robert-Bosch-Straße 17 | 77656 Offenburg
Tel.: +49 781 600-0 | info@hobart.de
www.hobart.de
Zentraler Verkauf +49 180 300 0068

Service:

Werkskundendienst +49 800 600 1313
für Österreich +43 820 240 599

SCHWEIZ

GEHRIG GROUP AG

Bäulerwisenstrasse 1 | 8152 Glattbrugg
Tel.: +41 43 211 56-56
info@gehriggroup.ch
www.gehriggroup.ch

FRANCE

COMPAGNIE HOBART

ZI PARIS EST - Allée du 1er Mai - B.P. 68
77312 MARNE LA VALLEE Cedex 2
Téléphone: +33 1 64 11 60 00
contact@hobart.fr
www.hobart.fr

UNITED KINGDOM

HOBART UK

Southgate Way | Orton Southgate
Peterborough | PE2 6GN
Phone: +44 844 888 7777
customer.support@hobartuk.com
www.hobartuk.com

BELGIUM

HOBART FOSTER BELGIUM

Industriestraat 6 | 1910 Kampenhout
Phone: +32 16 60 60 40
sales@hobart.be
www.hobart.be

NEDERLAND

HOBART NEDERLAND B.V.

Pompmolenlaan 12 | 3447GK Woerden
Tel.: +31 348 46 26 26
info@hobart.nl | www.hobart.nl

NORGE

HOBART NORGE

Gamle Drammensvei 120 A | 1363 HØVIK
Tel.: +47 67 10 98 00
post@hobart.no | www.hobart.no

SVERIGE

HOBART SCANDINAVIA APS

Varuvägen 9 | 125 30 Älvsjö
Tel.: +46 8 584 50 920
info@hobart.se | www.hobart.se

DANMARK

HOBART SCANDINAVIA APS

Håndværkerbyen 27 | 2670 Greve
Tel.: +45 43 90 50 12
salg@hobart.dk | www.hobart.dk

AUSTRALIA

HOBART FOOD EQUIPMENT

Unit 1/2 Picken Street | Silverwater NSW | 2128
Tel.: +61 2 9714 0200
www.hobartfood.com.au

SPAIN

HOBART ESPAÑA

DIVISION DE ITW ESPAÑA, S.L.U.

Ctra de Ribes KM 31,7
08520 Les Franqueses del Vallés, Barcelona
Phone +34 938 605 020
info@hobart.es | www.hobart.es

KOREA

HOBART KOREA LLC

7th Floor | Woonsan Bldg | 108 | Bangi-dong
Songpa-gu | Seoul 138-050
Phone: +82 2 34 43 69 01
contact@hobart.co.kr
www.hobart.co.kr

JAPAN

HOBART (JAPAN) K.K.

Suzunaka Building Omori
6-16-16 Minami-Oi | Shinagawa-ku | Tokyo 140-0013
Phone: +81 3 5767 8670
info@hobart.co.jp | www.hobart.co.jp

SINGAPORE

HOBART INTERNATIONAL (S) PTE LTD

158 | Kallang Way | #06-03/05
Singapore 349245
Phone: +65 6846 7117
enquiry@hobart.com.sg
www.hobart.com.sg

THAILAND

HOBART (THAILAND)

43 Thai CC Tower Building | 31st FL
Room No. 310-311 | South Sathorn Rd.
Yannawa | Sathorn | Bangkok | 10120
Phone: +66 2 675 6279 81 | enquiry@hobartthailand.com
www.hobartthailand.com

OTHER COUNTRIES

HOBART GMBH

Robert-Bosch-Straße 17 | 77656 Offenburg | Germany
Phone: +49 781 600-2820
info-export@hobart.de
www.hobart-export.com