

TECHNICAL DATA SHEET FOR

10 Litre Planetary Mixer

BM10AT

STANDARD FEATURES

- Heavy duty construction
- Belt driven
- Long life gear box
- 3 fixed speeds
- Easy speed shifting
- 15 minute timer

STANDARD ACCESSORIES

- Batter beater
- Dough hook
- Wire whisk
- 10 litre stainless steel bowl
- Wire safety guard
- Scraper



BM10AT



BM10AT without guard

OPTIONAL ACCESSORIES

- BM10AT-12-001 Stainless steel bowl to suit 10 litre mixer
- BM10AT-12-002 Batter beater to suit 10 litre mixer
- BM10AT-12-003 AL hook to suit 10 litre mixer
- BM10AT-12-004 Stainless steel wire whip to suit 10 litre mixer

TECHNICAL DATA SHEET FOR

10 Litre Planetary Mixer

BM10AT

SPECIFICATIONS

Electrical Requirements

220-240V, Single Phase 10amp 0.25kW

Cordset fitted

External Dimensions

Width 365mm

Height 630mm

Depth 453mm

Nett Weight

62kg



Australia
www.moffat.com.au
New Zealand
www.moffat.co.nz

Australia
Moffat Pty Limited
Victoria/Tasmania
740 Springvale Road
Mulgrave, Victoria 3170
Telephone 03-9518 3888
Facsimile 03-9518 3833
vsales@moffat.com.au

New South Wales
Telephone 02-8833 4111
nswsales@moffat.com.au

South Australia
Telephone 03-9518 3888
vsales@moffat.com.au

Queensland
Telephone 07-3630 8600
qldsales@moffat.com.au

Western Australia
Telephone 08-9202 6820
bgarcia@moffat.com.au

New Zealand
Moffat Limited

Christchurch
16 Osborne Street
Christchurch 8011
Telephone 03-389 1007
Facsimile 03-389 1276
sales@moffat.co.nz

Auckland
Telephone 09-574 3150
sales@moffat.co.nz

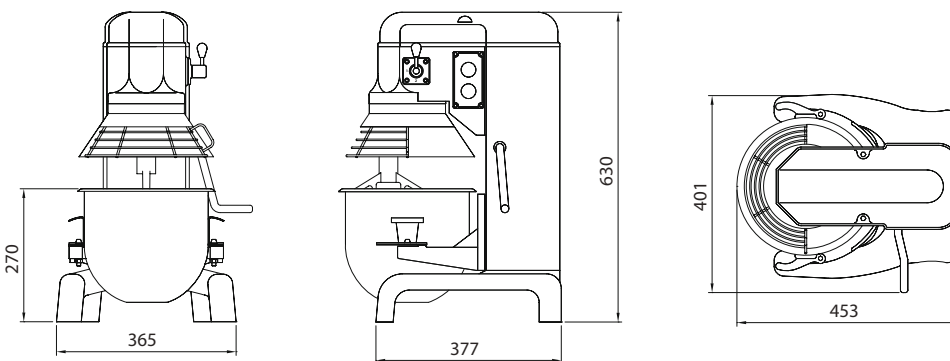

In line with policy to continually develop and improve its products, Moffat Limited reserves the right to change specifications and design without notice.

