

# Convotherm 4 easyDial Combi Steamer

**C4ESD12.20C** ELECTRIC DIRECT STEAM 24 x 1/1GN or 12 x 2/1GN

- Direct steam system
- ACS+ (Advanced Closed System +) operating modes: Steam, Combi-steam, Convection
- ACS+ Extra Functions:
  - Crisp&Tasty - 5 moisture-removal settings
  - BakePro – 5 levels of traditional baking
  - HumidityPro - 5 humidity settings
  - Controllable fan – 5 speed settings
- easyDial: all functions can be set on one operating level
- ConvoClean fully automatic cleaning system
- HygienicCare
- USB port integrated in the control panel
- TriColor indicator ring - indicates the current operating status
- Steam generated by injecting water into the cooking chamber
- Right-hinged appliance door



## Standard Features

- ACS+ operating modes:
  - Steam (30-130°C) with guaranteed steam saturation
  - Combi-steam (30-250°C) with automatic humidity adjustment
  - Convection (30-250°C) with optimised heat transfer
- HygienicCare: safety through antibacterial surfaces
  - easyDial control panel
  - Door handle and recoil hand shower
- easyDial user interface:
  - Central control unit, Convotherm Dial (C-Dial)
  - Digital display
  - Regenerating function - regenerates products to their peak level
  - 99 cooking profiles containing up to 9 steps
- Multi-point core temperature sensor
- Door handle with safety latch
- Built-in preheat bridge
- RS232 and RS485 interface
- Data storage for HACCP figures
- Preheat and Cool down function
- ConvoClean fully automatic cleaning system, including optional single-measure dispensing

## Options

- Steam and vapour removal (built-in condensation hood)
- Grill model with grease collection
- Marine model
- Ethernet / LAN interface
- Available in various voltages
- Sous-vide sensor, with external socket
- Core temperature sensor, with external socket

# Convotherm 4 easyDial Combi Steamer

## C4ESD12.20C ELECTRIC DIRECT STEAM 24 x 1/1GN or 12 x 2/1GN

Front view

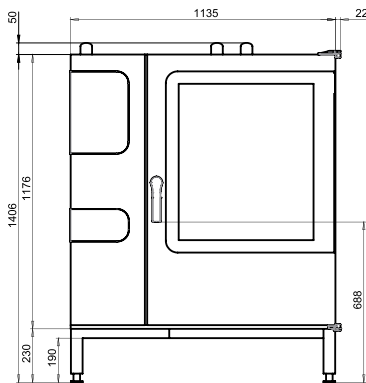

View from above with wall clearances

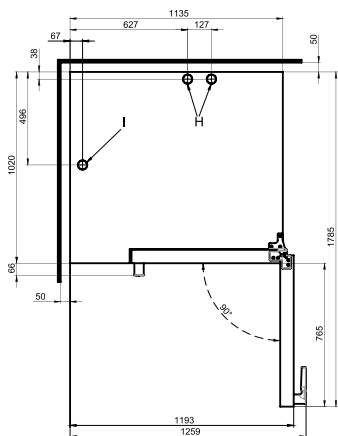

Connection positions in appliance floor

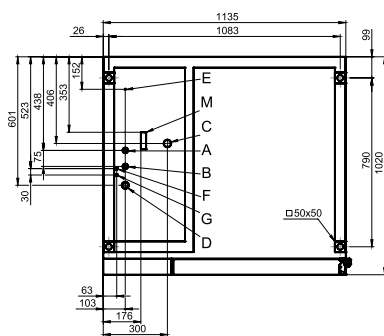

- A** Water connection (for water injection)
- B** Water connection (for cleaning, recoil hand shower)
- C** Drain connection DN 50
- D** Electrical connection
- E** Equipotential bonding
- F** Rinse aid connection
- G** Cleaning agent connection
- H** Air vent Ø 50 mm
- I** Ventilation port Ø 50 mm
- M** Safety overflow 80 mm x 25 mm

### DIMENSIONS

Width	1135 mm
Depth	1020 mm
Height	1406 mm
Weight	235kg

### PACKED DIMENSIONS

Width	1410 mm
Depth	1170 mm
Height	1615 mm
Weight (including cleaning system)	280 kg

### Safety clearances\*

Rear	50 mm
Right	50 mm
Left (larger recommended for servicing)	50 mm
Top (for ventilation)	500 mm

\*Heat sources must lie at a minimum distance of 500 mm from the appliance.

### INSTALLATION REQUIREMENTS

For precise installation instructions please refer to the units installation manual

### LOADING CAPACITY

<b>Max. number of food containers</b>	
Shelf distance	68mm
GN 1/1 (with standard loading trolley)	24
GN 2/1 (with standard loading trolley)	12
<b>Max. loading weight GN 1/1 / 600 x 400</b>	
Per combi steamer	120 kg
Per shelf	15 kg

### ELECTRICAL SUPPLY

<b>3N~ 400V 50/60Hz (3P+N+E)</b>	
Rated power consumption	33.7 kW
Rated current	48.7 A
Fuse	50 A
RCD (GFCI), frequency converter	Type A
(singlephase)	(recommended), type B/F (optional)

Special voltage options available on request.

Connection to an energy optimisation system as standard.

### WATER CONNECTION

**Water supply**  
2 x G 3/4" permanent connection, optionally including connecting pipe (min. DN13 / 1/2")

Flow pressure 150 - 600 kPa (1.5 - 6 bar)

### Appliance drain

Drain version Permanent connection (recommended) or funnel waste trap  
Type DN50 (min. internal Ø: 46 mm)  
Slope for waste-water pipe min. 3.5% (2°)

### WATER QUALITY

**Drinking water**  
(install water treatment system if necessary)  
Treated tap water for water injection  
Untreated tap water for cleaning, recoil hand shower

**Total hardness**  
Injection (soft water) 4-7 °dh / 70-125 ppm / 7-13 °TH / 5-9 °e

Cleaning, recoil hand shower (hard water) 4-20 °dh / 70-360 ppm / 7-35 °TH / 5-25 °e

### Properties

pH	6.5 - 8.5
Cl <sup>-</sup> (chloride)	max. 60 mg/l
Cl <sub>2</sub> (free chlorine)	max. 0.2 mg/l
SO <sub>4</sub> <sup>2-</sup> (sulphate)	max. 150 mg/l
Fe (iron)	max. 0.1 mg/l
Temperature	max. 40°C
Electrical conductivity	min. 20 µS/cm

### EMISSIONS

<b>Heat output</b>	
Latent heat	6900 kJ/h / 1.92 kW
Sensible heat	7800 kJ/h / 2.17 kW
<b>Waste water temperature</b>	max. 80 °C
<b>Noise during operation</b>	max. 70 dBA



Australia  
moffat.com.au

New Zealand  
moffat.co.nz

Australia  
Moffat Pty Limited

Victoria/Tasmania  
740 Springvale Road  
Mulgrave, Victoria 3170  
Ph 03-9518 3888  
Fax 03-9518 3833  
vsales@moffat.com.au  
www.moffat.com.au

New South Wales  
Ph 02-8833 4111  
nswsales@moffat.com.au

South Australia  
Ph 03-9518 3888  
vsales@moffat.com.au

Queensland  
Ph 07-3630 8600  
qldsales@moffat.com.au

Western Australia  
Ph 08-9413 2400  
wasales@moffat.com.au

New Zealand  
Moffat Limited

Christchurch  
45 Illinois Drive  
Izone Business Hub  
Rolleston 7675  
New Zealand  
Telephone +64 3-983 6600  
Facsimile +64 3-983 6660  
sales@moffat.co.nz

Auckland  
Ph +64 9-574 3150  
sales@moffat.co.nz

In line with policy to continually develop and improve its products, Moffat Limited reserves the right to change specifications and design without notice.

© Copyright Moffat Ltd  
AN.CON.S.1901

