

HD2S

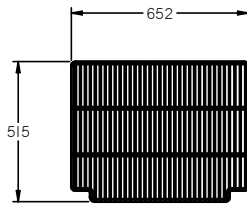

CATEGORY	GENERAL UPRIGHTS
RANGE	Diamond
UNIT	REFRIGERATOR
TYPE	SELF CONTAINED
DOORS	2



SHELF DETAIL

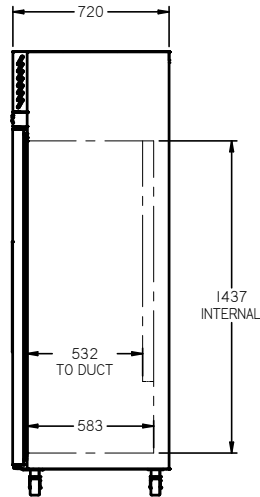
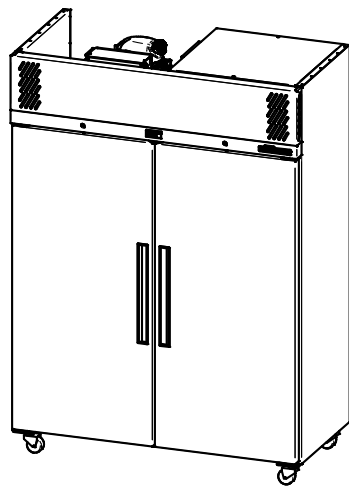
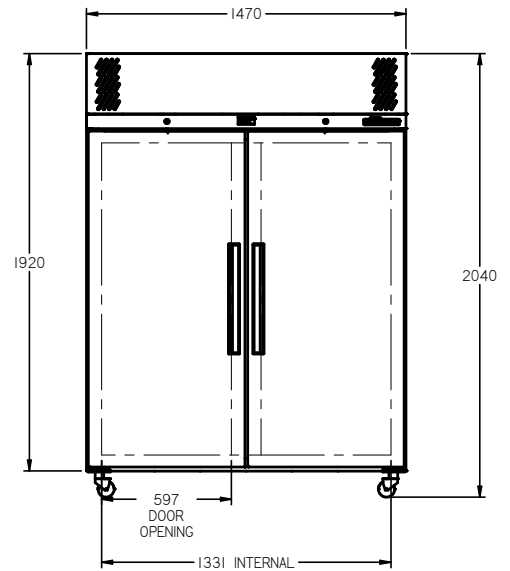
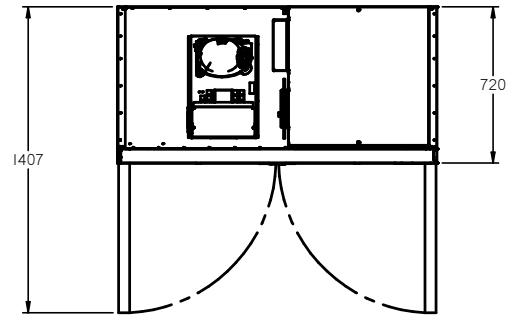

SPECIFICATIONS

CAPACITY LITRES	1100
TEMPERATURE	1°C / 4°C
DIMENSIONS - W X D X H (ON 120 MM H CASTORS) MM	1470 W x 720 D x 2040 H
WEIGHT UNPACKED (KG)	250

STANDARD INCLUSIONS ***

DOOR TYPE	S (Solid Door), Optional: PT (Pass Through)
FINISH (INTERIOR AND EXTERIOR EXCLUDING REAR AND UNDER)	W (White), B (Black), S (Stainless Steel)
SHELVES/DOOR (ADJUSTABLE STRIPS AND CLIPS)	4

GAS TYPE

REFRIGERANT	R134a
-------------	-------

ELECTRICAL

POWER SUPPLY	10 amp
POWER CABLE LENGTH (METRES)	2
RUNNING AMPS	3.2

PERFORMANCE

KWH/24H READING	4.9
TEST STANDARD	EN 16825 (Professional)
TEST CONDITIONS	4 M1
AMBIENT RATING	43°C

REFRIGERATION WATTAGES FOR OPTIONAL REMOTE UNITS

FRIDGE MODELS - SOLID DOORS (R404A)	630 @ -5°C SST
-------------------------------------	----------------

*** For **OPTIONS** refer to the current Williams Price Guide