

## TECHNICAL SPECIFICATION SHEET FOR

# Blue Seal Electric Combi Steamer S LINE COMPACT EC1011CSDW 10 x 1/1GN

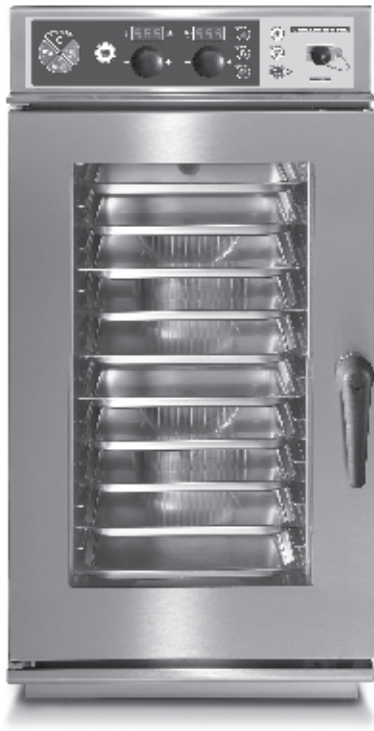

- Compact 510mm wide
- Manual controls
- High visibility alphanumeric display
- Multipoint core temperature probe
- Ecospeed – less energy consumption by regulating temperature fluctuation
- Ecovapor system - automatic steam saturation control
- Two speed fan
- Over 90 preset recipe programs
- Programmable with 99 programs with automatic 4 cycle sequence
- CLIMA control 30° to 300°C
- Auto-reversing fan rotation
- Autoclima with automatic vent
- CLIMA system to control the percentage of humidity during cooking
- Hand shower
- Semi automatic washing programme
- Fully automatic wash system
- 4 LED's to indicate actual cooking cycle in programme mode
- USB connection for program updating and HACCP data download
- Rack runners for GN loading

### GENERAL FEATURES:

- Direct steam injection system
- Stainless steel construction
- Hygienic rounded corners in oven cavity
- Pivoting fan suction panel
- Top removable control panel for easy servicing
- Hygienic plug-in door seal for easy to remove day-to-day cleaning
- Adjustable door hinges
- Self draining door condensate drip tray
- Oven door handle mechanism allows either left or right operation
- Cool to touch double glazed door
- Hinged inner glass for easy cleaning
- Constant self-diagnosis for error recognition

### OPTIONAL FEATURES:

- Right hinged door
- Marine and special voltages
- Side runners for 530 x 325 trays (10 trays)

## TECHNICAL SPECIFICATION SHEET FOR Blue Seal Electric Combi Steamer S LINE COMPACT EC1011CSDW 10 x 1/1GN

### Dimensions

Width	510mm
Height	970mm
Depth	800mm
Weight	90kg

### Packed Dimensions

Width	570mm
Height	1130mm
Depth	930mm
Weight	103kg

### Shelves

1/1 GN	10
Shelf Spacings	60mm

### Installation requirements

(for precise installation instructions, please refer to the unit's installation manual).

### Power connection requirements

Multi pole circuit breaker and all pole disconnection isolator switch installed near the appliance.

Supply line voltage;  
400-415V ~ 50Hz, 3P+N+E

Special voltage options available on request.

### Power Connection

Total (kW)	15.5
Convection power (kW)	15
Rated Current (A) (400V)	22

IPX5 spray-proof and hose proof.

### Installation clearances

- rear	50mm
- right	500mm
- left	100mm

\*Clearance required on fixed installations for service accessibility.

If heat sources are located near the RH side of the combi, ensure that a minimum distance of 500mm is maintained.

Install in accordance with local body regulations only on horizontal surfaces and not against combustible walls.

### Water connection requirements

- cold water
- flow pressure (200-500kPa)
- soft water connection\*
- shut-off valve with return flow inhibitor and dirt filter
- water supply 2 x R3/4
- R40 waste water connection

(\*Water softener may be required. Please refer to installation manual for water treatment values.)

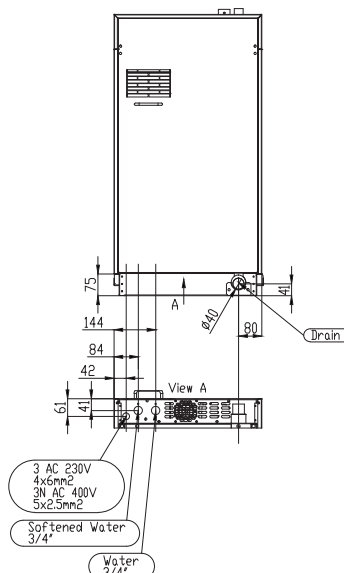
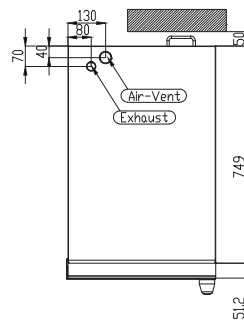
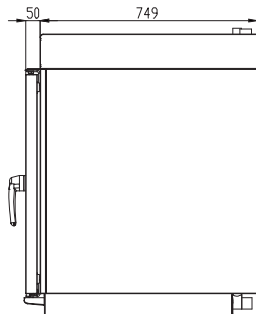
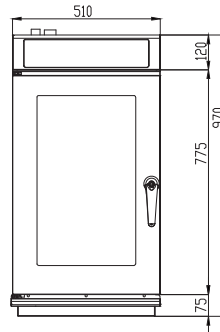

**MOFFAT®**

Australia  
[www.moffat.com.au](http://www.moffat.com.au)

New Zealand  
[www.moffat.co.nz](http://www.moffat.co.nz)

Australia  
Moffat Pty Limited

Victoria/Tasmania  
740 Springvale Road  
Mulgrave, Victoria 3170  
Ph 03-9518 3888  
Fax 03-9518 3833  
[vsales@moffat.com.au](mailto:vsales@moffat.com.au)  
[www.moffat.com.au](http://www.moffat.com.au)

New South Wales  
Ph 02-8833 4111  
[nswsales@moffat.com.au](mailto:nswsales@moffat.com.au)

South Australia  
Ph 03-9518 3888  
[vsales@moffat.com.au](mailto:vsales@moffat.com.au)

Queensland  
Ph 07-3630 8600  
[qldsales@moffat.com.au](mailto:qldsales@moffat.com.au)

Western Australia  
Ph 08-9202 6820  
[bgarcia@moffat.com.au](mailto:bgarcia@moffat.com.au)

New Zealand  
Moffat Limited

Christchurch  
16 Osborne Street  
Christchurch 8011  
Ph +64 3-389 1007  
Fax +64 3-389 1276  
[sales@moffat.co.nz](mailto:sales@moffat.co.nz)

Auckland  
Ph +64 9-574 3150  
[sales@moffat.co.nz](mailto:sales@moffat.co.nz)



In line with policy to continually develop and improve its products, Moffat Limited reserves the right to change specifications and design without notice.

