

DETAILS



1. Opening door alarm/Hi temperatura alarm
2. Blue backlit main switch
3. Fixed evaporator shelves

GENERAL FEATURES

200 Lt. Freezer upright (CLASS A)	•
S/S external cabinet, thermoformed internally	•
Static cooling: fixed evaporator shelves (N.2 Layers) with fan assisted cooling	•
Manual defrost	•
Foaming Agent Cyclopentane (50mm per side)	•
Digital Thermostat	•
Opening door alarm/Hi temperatura alarm	•
Removable Gasket	•
Reversible door with stainless steel external handle	•
Lock and main switch fitted as standard	•
N.2 Adjustable feet + N.2 Rollers at the back	•
Energy efficiency class: A	•

SIZES

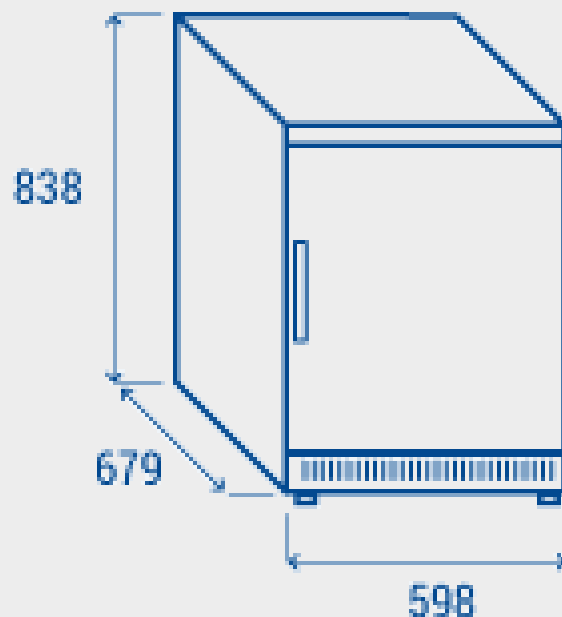

TECHNICAL SPECIFICATION

INNER DEPTH	478 mm
INNER HEIGHT	635 mm
INNER WIDTH	493 mm
DEPTH	679 mm
HEIGHT	838 mm
WIDTH	598 mm
KW/24H	1.25 Kw
CAPACITY	200 L
NOISE LEVEL	40 dB(A)
CONSUMPTION	80 W
NET WEIGHT	41 Kg
TEMPERATURE RANGE	-23°C ~ -18°C

CERTIFICATIONS

