



Goldstein

800 SERIES FRYER

3 baskets



FRE24DL - Electric

- High efficiency - all the energy goes into the oil
- Unique pan design maximises heat transfer to minimise energy use
- Digital thermostat
- Stainless steel pan for easy cleaning
- Stainless steel baskets
- Front cool zone with crumb arrester for longer oil life
- Night lid
- Cover/joiner strips available for multi-unit installations

Other options

Castors and tether

Cover/joiner strips

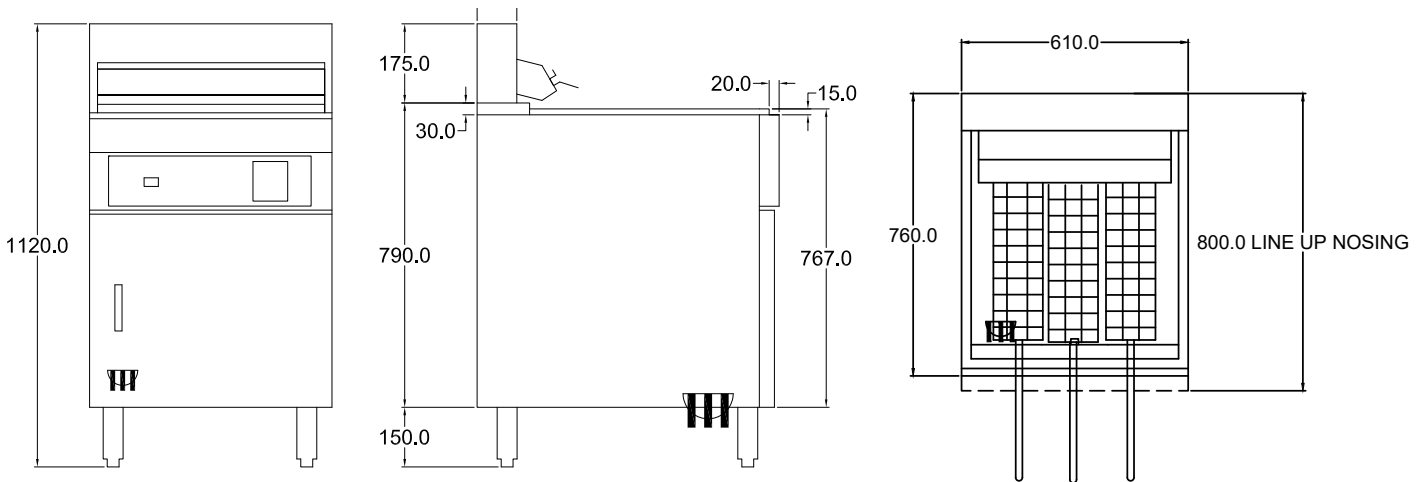

FRE24DL 3 baskets

SPECIFICATIONS

Dimensions (WxDxH)	610 x 800 x 1120 mm
Working height	900 mm (±20 mm)
Pan Size (WxDxH)	555 x 390 x 275 mm
Capacity	45 L

3 Phase (415V+N+E) 7Kw/Ph

Electric Connection	3 phase, 415V+N+E
Rating	21 kW
Weight	90 kg
Packed	0.6 m ³

Australia's premier food service
equipment manufacturer

middleby.com.au

211-217 Woodpark Road, Smithfield NSW 2164
1800 013 123 | +61 2 9604 7333

MIDDLEBY AUSTRALIA

