



** Shown with optional double rack insert

TECHNICAL DATA

Cycle times (*)	90 / 180 / 360 sec. and special cycles
Water consumption	2 l/rack
Tank capacity	10.6 l
Tank heating	0.8 kW
Power supply	240/50/1 (415/50/3N)
Booster loading	
Standard	1.36kW
Alternative	6.15kW
Total loading	
Standard	2.9kW 15amp
Alternative	7.7kW 15amp (3ph)
Wash pump	0.6 kW 350 l/min
Rack size	500 x 500 500 x 530 mm
Loading height	425 mm
Noise level	60.5 dB (A)
Weight (gross / net)	70 / 60 kg

CONNECTIONS

① Drain hose	2,000 mm ID20/OD25
② Supply hose	2,000 mm R 3/4"
Flow pressure	0.5 (0.8 with softener) - 10 bar
Max. supply water temperature	60 °C
Required flow rate	5 l/min
③ Power cord	2,000 mm
Supply hose for	
④ Detergent	2,500 mm
⑤ Rinse aid	2,500 mm

* Thermostop guarantees required rinse temperatures. The actual cycle time extends accordingly if the machine is connected to cold water.

* For machine protection water hardness should not exceed 3°dH. If higher we recommend using a water softener - ask your Hobart representative for assistance.

PRODUCT ADVANTAGES

- **VISIOTRONIC Control:** ensures a simple and intuitive operating with a single button. When the display is activated by a proximity sensor, all the necessary information appears in the large display, in clear text or in the form of symbols
- **SENSO-ACTIVE Resource Management:** constantly measures the quality of the wash water and keeps the amount of rinsing needed in each rinse cycle to the minimum in order to guarantee a fully hygienic wash result. This reduces the amount of fresh water used per rinse cycle up to 2.0 l
- **Double rack system:** two racks can be washed in a single wash cycle. One rack of cups can be washed underneath, while a second rack containing dishes and cutlery can also be washed above it. Thanks to the optimum use of the entire wash chamber the performance of the machine can be doubled
- **Under counter glass and dishwasher with optional double rack insert**
- **Nominal capacity up to 40 racks/h 720 plates / h or 1,440 glasses / h.** Potential for doubling with double rack insert
- **6 automatic cycles:** short, standard, water X change, starch removal, permanent, hygiene
- **Heat and noise insulated**
- **Self cleaning program**
- **CLIP-IN Wash and Rinse Arms:** both the wash and rinse arms can be lifted out of the wash chamber and replaced with one hand and without any tools
- **Intelligent data documentation:** automatic recording of important operational data and consumptions and indication on the display
- **USB-interface:** comfortable download of operational data in form of a protocol via USB
- **Fill level indicator:** monitors contents of external as well as integrated chemical containers
- **Filter position sensor:** prevents operation without tank strainer
- **GENIUS-X² Fine Filter System:** advanced filter system with pre-wash function reduces detergent consumption up to 35%
- **Hygiene Programme:** for removal of calcium carbonate and other deposits from wash chamber
- **Ready to install - equipped with:** fill/drain hoses, electrical cable (240V), detergent & rinse aid dispensers, rinse pump, drain pump, back flow preventer (Watermark approved)
- **Tank, frame, wash/rinse arms & panels are 1.4301 stainless steel**
- **1 - plate rack P-18-12**
- **1 - universal rack B-00-07**
- **1 - 4 section cutlery basket CB4**

DIMENSIONAL DRAWING

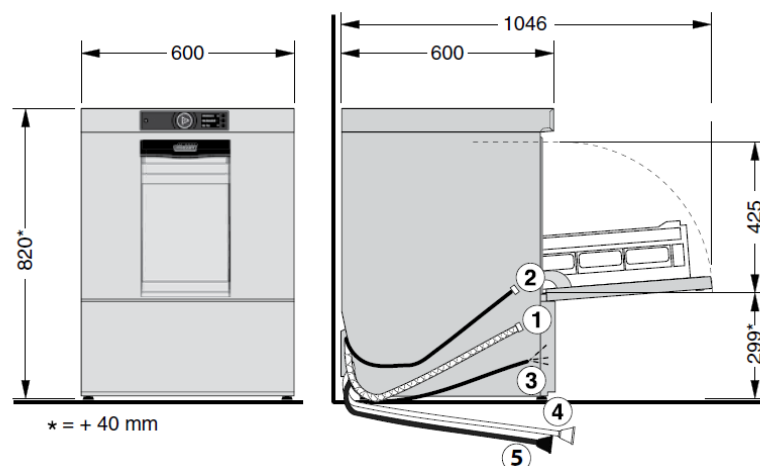

MADE IN GERMANY