

GALA

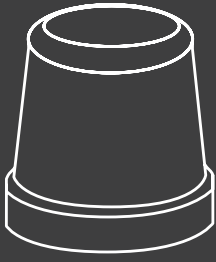

MDP150 A

Modular Ice Cube Maker

SKOPE®

ITV | ICE makers



Features



- 150kg ice cube production in 24 hours
- Produces pure and clear, solid ice cubes
- Perfectly separated and consistent in size
- 150kg ice storage capacity
- Easy access external operational switches
- Strong solid AISI 304 stainless steel box-type frame
- Easy servicing without disassembling the whole machine
- Patented robust folding door with noise reduction system
- Flexible nozzle spray system to reduce build up of limescale
- Front and rear ventilation system allows machine to be built-in (ventilation clearances required)
- Cleaning switch allows circulation of water with descaling product (calklin or similar)
- Tropical T Class compressors suitable for use in environments up to 43°C ambient
- ITV designed motor pump, no seals to avoid deterioration
- Designed to allow easy disassembly and servicing for minimal disruption
- 2 year warranty
- **Installation must be carried out by a qualified plumber or refrigeration mechanic**

Supplied Accessories



Water Inlet
Hose



Drain Hose



Gasket
Washers



Medium
Scoop



Adjustable
height legs

Water Filter



A Watermark approved* water filter, suitable for the water type at the place of installation must be used. SKOPE can provide a water filter that protects the Ice Maker, and ensures proper function and high quality ice production. Service or repair due to absence of a suitable water filter will not be covered by SKOPE warranty. Contact SKOPE for more information.

*Watermark approval is only applicable to Australian installations. Elsewhere, a suitable water filter must be used

Machine Specifications

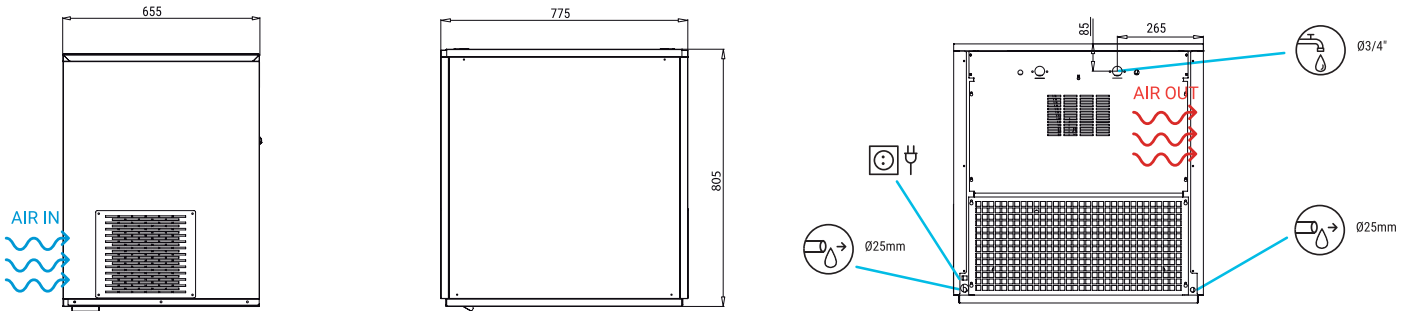

Machine dimensions	775 x 625 x 805mm
Packed dimensions	845 x 715 x 990mm
Machine weight	93kg
Packed weight	103kg
Floor area	0.6m ²

Ventilation recommendations

- 100mm behind the cabinet
- 100mm above the cabinet

(W)	(Btu/h)	(W) 43°C	(n.) (mm ²)	FUSE	(Kwh)	(l/h)	(W) (Btu/h)			
	1195	4,078	1,200	3	1.5	16	19	22	2,647	9,032

Ice Specifications



Ice dimensions	35 x 35 x 30mm
Ice cube volume	23/30cc
Ice cubes per cycle	84
Ice cube storage capacity	150kg

Ice production per 24 hour cycle (kg)

		Water temperature			
		10°C	15°C	21°C	30°C
Air temperature	10°C	163	161	142	118
	21°C	151	150	130	106
	32°C	138	136	116	92
	43°C	104	102	83	59



Electrical Safety & EMC
Regulatory Compliance Mark



2 Year Warranty Protection
Parts & Labour

SKOPE INDUSTRIES LIMITED

Australian Freephone: 1800 121 535
New Zealand Freephone: 0800 947 5673
Email: skope@skope.com
Website: www.skope.com