

Technical data sheet for

## GAS GRIDDLE 900mm

GP516-B, GP516-CB, GP516-LS, GP516-RB

- Heavy-duty thermostatic gas griddle
- 20mm thick griddle plate
- Ribbed plate options
- Mirror chromed plate options
- Top weld sealed plates
- 80MJ thermostatic burner system
- Separate left and right heat zones
- 3 models of base unit
- 1 model of ventilated 2 drawer refrigeration base
- Rear rollers
- Stainless steel exterior
- Easy clean
- Easy service
- Fully modular

### Overall Construction

#### Griddle

- 20mm thick machined top plates standard
- Optional ribbed plate sections
- Optional mirror finish hard chrome plates
- 2.5mm thick 304 stainless steel splash guards sides and rear
- 2.0mm thick grease channel
- Two 40MJ 3 bar even heat burners with dual thermostatic controls
- Full pilot and flame failure protection with piezo ignition
- Welded hob surround with 1.5mm 304 stainless steel bull nose
- Side panels 1.2mm 304 stainless steel
- Splashback 1.2mm 304 stainless steel
- Vitreous enamelled control panel
- Stainless steel grease drawer
- Overlapping finish at front and rear of plate for easy clean

#### Bench mount (supplied as -B model)

- Four 63mm dia. heavy-duty 1.2mm 304 stainless steel bench legs with adjustable feet.
- Adjustable height 80mm – 105mm

#### Cabinet base (supplied as -CB model)

- Fully modular for match suite finish
- Double skin 0.9mm 304 stainless steel interior and exterior
- Optional GN 1/1 4 position racking kit (1 or 2 cabinet bays)
- Up to eight 65mm GN 1/1 capacity
- 63mm dia. heavy-duty 1.2mm 304 stainless steel legs with two adjustable feet at front and two rollers at rear

#### Leg Stand (supplied as -LS model)

- Fully modular for matched suite finish
- Framed top for connection to Griddle
- 63mm dia. heavy-duty 1.2mm 304 stainless steel legs with two adjustable feet at front and two rollers at rear
- Fully modular framed stand shelf with 0.9mm 304 stainless steel finish
- Suitable for rear or through shelf gas connection to Griddle
- Quick assembly design



GP516-LS

### Refrigerated base (supplied as -RB model)

- Self contained suite matched modular base
- Ventilated system with R134a refrigerant
- -2° to + 8°C temperature (Tropical Climate rated)
- Two GN 1/1 drawers
- 100mm deep pan capacity
- Heavy-duty European telescopic drawer guides
- Magnetic drawer gaskets (replaceable without tools)
- 50mm fully foamed CFC free insulation
- 304 stainless steel exterior and interior
- Anti-corrosion treated evaporator
- No condensate drain required
- 63mm dia. heavy-duty 1.2mm 304 stainless steel legs with adjustable feet
- Condensing unit removable through front of unit for service
- Easy clean interior

### Controls

#### Griddle

- Separate left and right side heat zones
- Two 90-300°C thermostats
- Large easy use control knobs - heat resistant reinforced
- Easy view control settings on knobs
- Flame failure pilot burners
- Piezo ignition to each pilot burner
- Over-temperature safety cut-outs

#### Refrigerated base

- Digital control electronic thermostat
- Automatic defrost
- Automatic evaporation of defrost water
- -2 to +8°C temperature range

### Cleaning and Servicing

- All models with easy clean stainless steel external finish
- Plate is finished front and rear with overlap construction to remove cleaning traps
- Control service and gas conversion through front of unit
- Burner service requires plate removal
- Refrigerated Base condenser removable through front of unit

# Technical data sheet for GAS GRIDDLE 900mm

## Specifications

### Griddle

### Burner

Two 3 bar chromed steel burners  
Individual pilot, flame failure and piezo ignition

### Gas power

80MJ/hr, 22.2kW

### Plate

Cooking surface 892mm x 530mm, 4728cm<sup>2</sup>

### Gas connection

R<sup>3</sup>/<sub>4</sub> (BSP) male

All units supplied with Natural and LP gas regulator

### Refrigerated base

#### Type

Ventilated system

#### Refrigerant

R134a [160grams]

#### Climate classification

T - tropical

#### Electrical connection

220-240Vac, 50Hz, 1.8A, 1P+N+E  
3 pin 10A plug cordset fitted

## Dimensions

### Bench models

Width 900mm  
Depth 812mm  
Height 315mm  
Incl. splashback 485mm

### All models (excluding Bench model)

Width 900mm  
Depth 812mm  
Height 915mm  
Incl. splashback 1085mm

## Packing data

### Bench and Leg Stand models

0.55m<sup>3</sup>  
Width 945mm  
Depth 870mm  
Height 665mm

### Cabinet Base and Refrigerated Base models

1.03m<sup>3</sup>  
Width 945mm  
Depth 870mm  
Height 1255mm

## Gas types

Available in Natural gas and LP gas, please specify when ordering  
Units supplied complete with gas type conversion kits  
Other gas types on request

## Options

Adjustable feet at rear  
Joining caps  
Castors  
Ribbed plate options  
Mirror chromed plate options

GP516-B

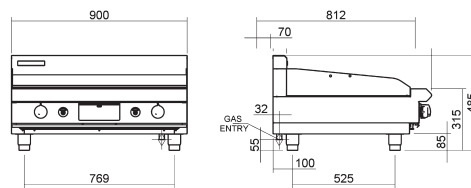

GP516-LS

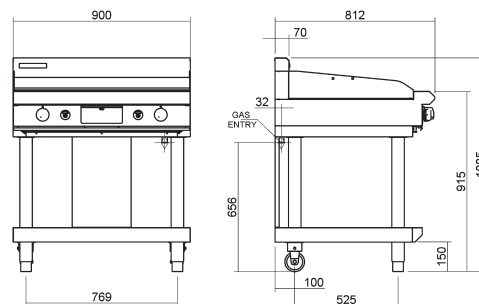

GP516-CB

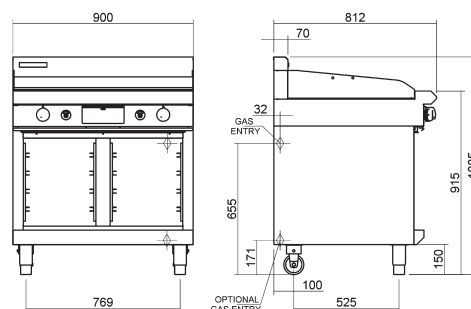

GP516-RB

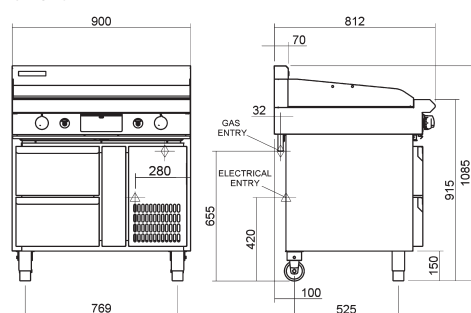

PLAN

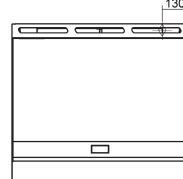

**MOFFAT**

Australia  
www.moffat.com.au  
New Zealand  
www.moffat.co.nz

www.bluesealevolution.com

Australia  
Moffat Pty Limited

Victoria/Tasmania  
740 Springvale Road  
Mulgrave, Victoria 3170  
Telephone 03-9518 3888  
Facsimile 03-9518 3833  
vsales@moffat.com.au

New South Wales  
Telephone 02-8833 4111  
nswsales@moffat.com.au

South Australia  
Telephone 03-9518 3888  
vsales@moffat.com.au

Queensland  
Telephone 07-3630 8600  
qldsales@moffat.com.au

Western Australia  
Telephone 08-9202 6802  
bgarcia@moffat.com.au

New Zealand  
Moffat Limited

Christchurch  
16 Osborne Street  
Christchurch 8011  
Telephone 03-389 1007  
Facsimile 03-389 1276  
sales@moffat.co.nz

Auckland  
Telephone 09-574 3150  
sales@moffat.co.nz



Designed and manufactured by

**MOFFAT**

ISO9001

All Blue Seal products are designed and manufactured by Moffat using the internationally recognised ISO9001 quality management system, covering design, manufacture and final inspection, ensuring consistent high quality at all times.



In line with policy to continually develop and improve its products, Moffat Limited reserves the right to change specifications and design without notice.

Printed in China  
© Copyright Moffat Ltd  
Moffat/4825/BH/2.5M/12.06

