

# CombiSlim 1.06



SmartTouch® display



Standard display

## COMBISLIM OVEN

6-tray combi oven (1/1 GN, 20/40 mm) or  
 4-tray combi oven (1/1 GN, 60 mm)  
 Electricity  
 Injection steam  
 SmartTouch® or Standard selection dial interface  
 2-piece rack  
 Temperature probe

## STANDARD SPECIFICATIONS

Voltage	400/415 V AC 3N
Wattage	8,4/ 9,2 kW
Power consumption	14 A
Water connection	3/4" outside
Drain	Ø 40 mm outside

## DIMENSIONS & WEIGHT

Width	513 mm
Height - table model	753 mm
Height with stand	1565 mm
Depth - table model	811 mm
Depth with stand	816 mm
Weight	67 kg

## ALTERNATIVE

Voltage	208/ 230/ 240 V AC 1N
Wattage	6,9/ 8,4/ 9,2 kW
Power consumption	39 A
Water connection	3/4" outside
Drain	Ø 40 mm outside

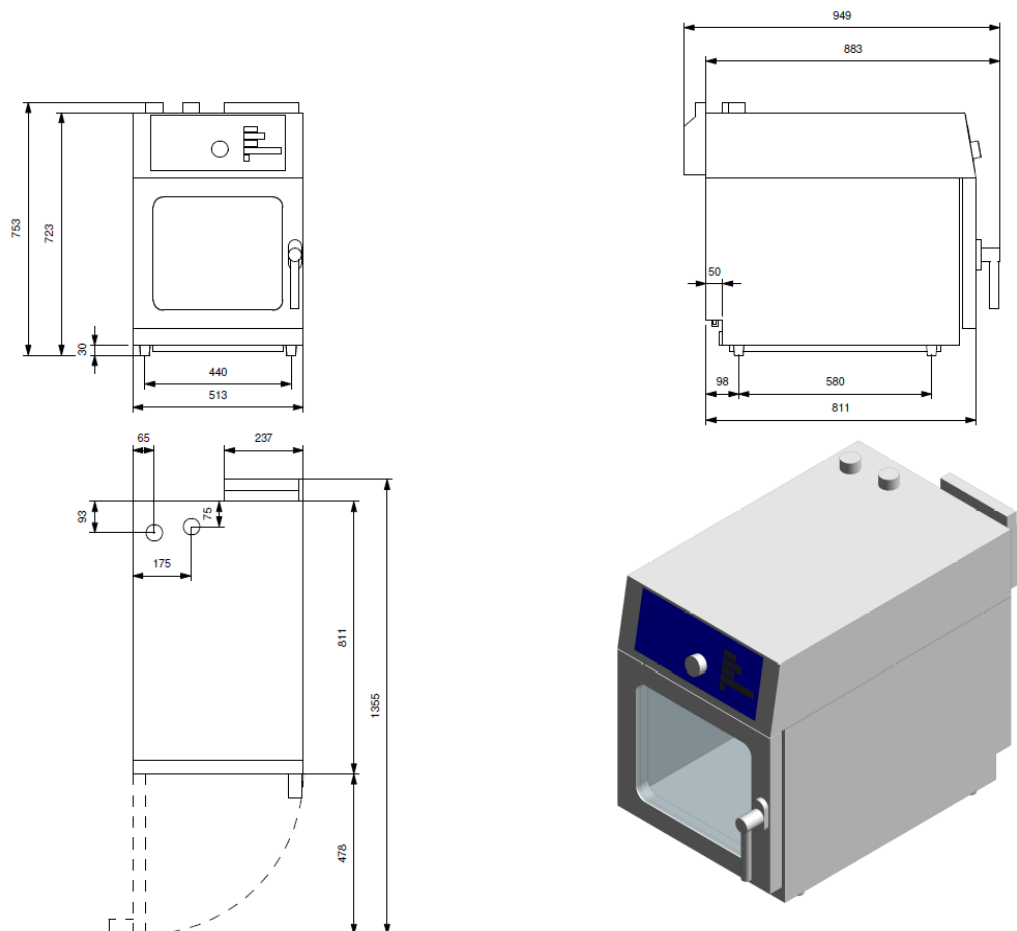

#### Cooking modes for Touch and Standard models:

- Hot air (Convection)
- Steaming
- Low-temperature steaming
- Forced steaming
- CombiSmart® humidity control, 10 steps
- Cook & Regen
- Proving, with automatic humidification
- Preheating
- Automatic cooling function
- Manual humidity pulsing
- Reversing, adjustable fan with 9 speeds

#### Additional cooking modes for Touch models:

- SmartChef®, automatic cooking
- Automatic humidity pulsing
- RackTimer®, with up to 20 timers
- Cool down function
- Delta-T
- Cook & Hold

#### Tested quality and safety:



#### Additional features for Touch and Standard models:

- Handshower
- CombiWash® automatic cleaning system
- HOUNÖ PROTECT start kit

#### Standard features for Touch models:

- HOUNÖ PROTECT start kit
- Chef's recipe collection
- Baker's recipe collection
- Favourites selection
- HACCP quality control, 60 days in PDF format
- USB connection

#### Additional features for Touch models:

- Let's Cook Cloud Solution
- CombiWash® automatic cleaning system
- Handshower
- Quick Select Recipes (QSR)
- Advanced Racktimer – for tailored menu handling
- Keypad – for temperature adjusting