

WARRANTY 3 YEARS
PARTS & LABOUR



Turbo air

NSW & VIC Rebate Eligible

UNDER COUNTER SOLID DOOR

Freezer
KUF12-2-N / KUF12-2(HC)
KUF12-2S-N / KUF12-2(600)(HC)

NATURAL Refrigerant Front Breathing

FEATURES / BENEFITS

■ Digital temperature control & monitor system

Keep food products safe by maintaining constant temperatures. External digital display allows for easy monitoring.

■ Hydrocarbon(HC) refrigerants (R-290)

With innovative and eco-friendly technology, Turbo Air brings you hydrocarbon refrigerators designed to meet DOE's Energy Conservation Standards in 2017 and to use EPA's SNAP Program approved HC refrigerants. Hydrocarbon refrigerants do not deplete the ozone layer and have very low affect to global warming (ODP-0, GWP-3).

■ Side mount compressor unit

With compressors positioned on the side of the unit, our refrigerators can now be serviced without being moved. Our innovative, front breathing feature also allows this model to be highly efficient in narrow spaces.

■ Exterior & interior of the cabinet

The Turbo Air K-series boasts a stainless steel exterior (galvanized steel back and bottom). Interior is stainless steel floor with AL sides, back and AL door liners. It guarantees the utmost in cleanliness and long product life. The K-series adds a touch of style to the most refined setting.

■ High-density polyurethane insulation

The entire cabinet structure and solid doors are foamed-in-place using high density, CFC free polyurethane insulation.

■ Hot gas condensate system

Through Turbo Air's creative innovation, the condensate system surfaces have been specially treated to resist corrosion. This not only increases efficiency without the risk of refrigerant leakage from corrosion, but also thoroughly prevents the overflow of condensate water.

■ Ergonomically designed doors

Customers' fatigue fades away with easy grip handles and doors that open effortlessly. These features along with self-closing doors make this the ultimate choice in customer convenience.

■ Adjustable, heavy duty, PE (polyethylene) coated

■ wire shelves

■ Easy open front grille with condenser cleaning

■ brush kit

Front grille cover is easily removable without any tools, which makes condenser cleaning easy and convenient at any time. Handy condenser cleaning brush is included inside the front grille cover.

■ Refrigerator holds 1°C ~ 8°C for the best in food preservation



Available in 700mm as standard and slim 600mm deep



■ LED interior lighting & fan control (only at Turbo Air)

Energy efficient LED lighting lights every corner, making items easy to find. Fan control function automatically shuts off the fan when the door is open, which prevents hot air from being drawn in, thus maintaining the cool inner temperature.

Standard features

- Anti-corrosion coated evaporator
- Self-contained system
- Standard 125mm. swivel castors with locks on the front set
- Door locks standard

Optional features

- 125mm castors fitted
- 180mm, 105mm, 80mm castors optional
- Adjustable legs 100-155mm,

REFRIGERATOR MANUFACTURER
Turbo air

■ WARRANTY: 3 Year Parts and Labour Warranty

UNDER COUNTER SOLID DOOR

Freezer
KUF12-2-N / KUF12-2(HC)
KUF12-2S-N / KUF12-2(600)(HC)

Model	KUF12-2-N(HC)	KUF12-2S-N(600)(HC)
Refrigerant	R-290	R-290
POWER INPUT(W)	400	400
COMP (HP)	2/5HP	1/3HP
Energy consumption KW/24H	3.75	3.77
AMPS(A)	2.5	2.5
Capacity (ℓ)	311	234
Product Dimension W (mm)	1200	1200
Product Dimension D (mm)	700	600
Product Dimension H (mm)	Min.Clearance height 860	Min.Clearance height 860
Weight (Kg)	84	71
Stainless steel	SUS 439	SUS 439
Applied castors	125mm	125mm
Max GN Pan depth	N/A	N/A
GN Pan	N/A	N/A
Door lock	yes	yes
Adjustable Shelves	2	2
LED light	Yes	Yes
Temperature range	-21°C~-12°C	-21°C~-12°C
Ambient temperature	35°C	35°C
Drainage / Forced Evaporation Type	Sop paper	Sop paper
Temperature control type	Digital control	Digital control
Cooling type	FAN COOLING	FAN COOLING
Glass Type (Low-e / Heater / How many layer of the glass)	N/A	N/A
Features	Easy filter cover Energy efficient	Easy filter cover Energy efficient
Design and specifications subject to change without notice. Actual Shipping weight may differ due to extra packing materials for product protection.		

PLAN VIEW

(unit : mm)

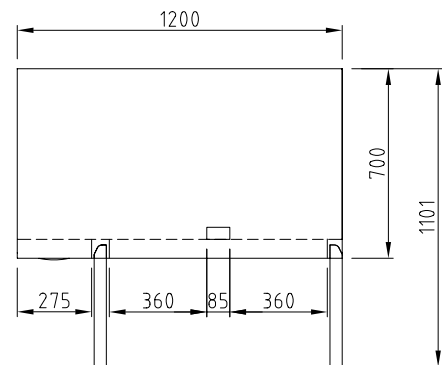

TOP VIEW

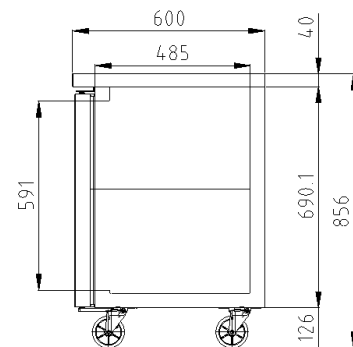

SIDE VIEW

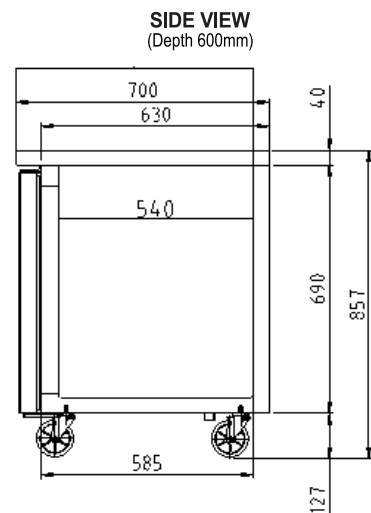

SIDE VIEW (Depth 700mm)

WARRANTY 3 YEARS
PARTS & LABOUR



AUSTRALIA BRANCH

Turbo air

email : TA.admin@turboairinc.com.au

23.01.24

TURBO AIR PTY LTD
www.turboairinc.com.au
 1st Floor, Building E
 10 Highgate St, Auburn
 NSW 2144 Australia
 T. 02 9737 9881