

WX 600mm Compact Woks



Technical Specifications for WX-1C



- Space saving 800mm depth
- 325mm wok ring suitable for standard sized woks
- Chimney burners ideal for high heat/fast stir frying
- Uses up to 90% less water than Traditional Woks
- Air gap design eliminates need for water cooling
- Machine pressed deck to prevent grime catchment
- Concealed ring lip prevents water from entering air gap
- Folding laundry arm for flexible usage positions
- Modular design to suit multiple WX wok units
- Optional Duckbill Burners no additional cost
- 15 month 'Platinum Warranty'

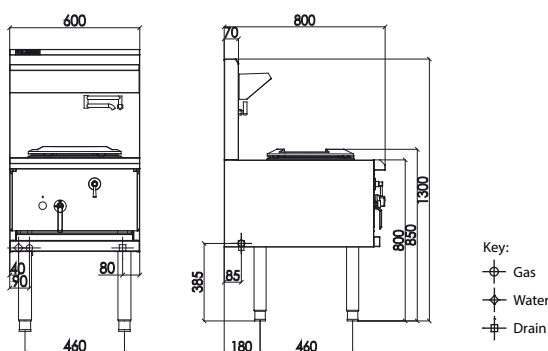

Compact Wok

- 115 mj 24 jet chimney burners with pilot & FFD
- 325mm diameter standard size cast-iron wok ring
- Air gap cooling system
- Quarter turn water control lever
- Folding rear laundry arm with front panel controls
- Front gutter design for easier cleaning
- Internal front heat shield panel
- Supplied with waste strainer
- Zinc-aluminium Alloy burner handles

Overall Construction

- Heavy duty construction
- Full skirt, enamelled cast-iron rings
- 1.5mm 304 stainless steel one-piece pressed deck
- 0.9mm 304 stainless steel condiment shelf
- Splashback 1.2 mm stainless steel
- Front cover and hob 1.2mm stainless steel
- Side panels 0.9mm stainless steel
- Undertrays 0.7mm stainless steel
- Stainless steel legs with 55mm height adjustment range

Dimensions

- 600mm x 800mm x 1300mm H
- Working height 800mm
- Weight 85kg
- Packed dimensions 650mm x 900mm x 1470mm H
- Packed weight 110kg

Connections

- Gas 3/4" BSP male
- Gas 90mm from left, 85mm from rear, 385mm to floor
- Supplied with gas regulator (specify Nat or LP on order)
- Water inlet 1/2" copper tube
- Water 560mm from left, 85mm to rear, 385mm to floor
- Drain 1/1/4" BSP male
- Drain 80mm from right, 85mm from rear, 385mm to floor

Cleaning & Servicing

- Easy access to all parts & components from front

Options/Accessories

- Knee lever timer tap
- Replace Chimney burners with Duckbill burners
- 250mm and 500mm wide clip on shelves
- Joining caps & strips
- RH and LH side shields
- Rear castors

	Model	Description	Nat Gas	LP Gas
	WX-1C	1 chimney burner wok	115 mj	115 mj

