

Master Series Heavy-Duty Equipment





Garland

Garland

Garland

Garland

Master The Art of Cooking

Create a custom workflow that fits your space, and your menu



Chefs around the world are already familiar with the performance, flexibility, and enduring prestige that comes with Garland's Master Series. Featuring a full compliment of range-top and range-base configurations, along with fryers, broilers, and more, the Master Series modular approach combines the convenience of custom kitchen design with proven, premium-quality components to deliver world-class functionality. The Master-equipped kitchen is a cooking environment where efficiency and safety are optimized without compromising freedom of culinary expression. That freedom is what transforms food into art. With Garland, you'll Master the Art of Cooking.

Performance

Master Series simply meets or beats your needs and expectations. Any time. Every time.

Precision

The control to boil, saute, simmer, fry, roast, bake, or broil with predicatable results for satisfying dining.

Power

Searing heat when technique demands it, and high-output speed when great service is important.

Consistency

Day in and day out, your staff will have the tools they need to serve up top-quality dishes without guesswork.

Flexibility

Master's modular design allows you to put the right operation in the right place for optimized workflow.

Reliability

With uncompromised durability in design and components, Master is always ready when the rush is on.

Convenience

One construction-matched line of products that does it all. Convenient planning. Convenient operation.

Safety

Thoughtful, ergonomic design and stay-cool touch points minimize mishaps and fatigue.

Contemporary

Lasting good looks with smooth surfaces and clean lines become the basis of your state-of-the-art kitchen.

Practical function and style with quality you've come to expect from...



1 Spectro-heat Tops

Spectro-heat tops help you target heat for greater control from rapid boil to simmer. Four stock pots can be accommodated at one time and can be maneuvered easily on the flat, even surface.

2 FDO Control and Piezo Spark Ignition

The FDO control allows you to achieve a consistent 150° holding temperature and a low-roasting capability at the turn of a dial. For easy start-ups, a piezo spark ignition system comes standard on all Master Series ovens.

3 Continuous Plate Rail

The deepest in the industry, the 7 1/2" continuous plate rail (up to 102" in length) has been engineered to provide a smooth, level work surface for even plating and less spillage when removing product from heat.

4 Two-piece Lift-off Sunfire Burners

Two-piece 35K (10.2 kW) lift-off Starfire burners are among the most powerful available. More heat means better technique and greater speed during high-demand periods.

5 Durable Tubular High Shelves

Tubular high shelves are contemporary in design and extremely strong and durable. Unlike closed-style shelves, they allow grease-laden vapors to escape, making cleaning easy.

6 Easy Cleaning Underneath

On multiple banked systems we've removed the double legs and casters between units for easier floor cleaning.

7 Cast-iron Oven Burner

A cast-iron oven burner at 40K BTUs (11.7kW) delivers powerful heat and lasts longer than traditional steel burners for increased performance and long-term reliability. Garland range-base ovens feature a natural, no-fan convection pattern for even browning.

8 Fryers

Garland fryers feature an infra-red "jet" burner and stainless steel pot warranted for life. The centerline thermostat is accurate within 1° F.

9 Quick and Safe Wipe-down

With a minimum of exposed fasteners, (many pieces have none!), the entire series is designed for safe and easy wipe-down.

10 Maximum Flexibility

Adapt your design to the available space easily using available 12" wide and/or 17" wide "attachment" models. 12" models available with (2) 24k open burners, griddle, or equa-therm hot top. 17" models available with (2) 35k open burners, griddle, equa-therm hot top, spectro-heat hot top, or char-broiler. Non-cooking "spreaders" are also available in different standard and custom sizes.

11 Grooved Griddle Option

For appetizing branding of grilled meats, fish, and vegetables..

12 Ergonomic Controls

Ergonomically designed control knobs are always "cool to the touch" and are recessed under the front rail, keeping them cool to the touch and out of way for protection against inadvertent mis-setting and bump-damage.

13 Charbroilers

Charbroilers generate up to 90,000 BTUs of cooking power and are ideally suited for both production line and à la carte cooking.

14 Storage

Full-width cabinet with left-and-right-swing stainless steel doors gives you a large, convenient storage area.

15 Safe Handles

Broiling rack salamander and warming oven control handles are easy to grab and located in the "cool zone" for added operator safety.

16 Clean-line Oven Door Handles

Clean-line handles have been engineered to dissipate heat. They also feature solid ends for easier cleaning.

17 Quick Access

Hinged lower panel gives you quick access to internal components without tools.



Master Series Ranges

High-Performance features that set the standard for heavy-duty cooking machines...



Stainless steel high-shelves and backguards have no exposed fasteners for enhanced safety and hygiene.

A comprehensive array of mix & match range top options include 24K Starfire open burners, 35K Starfire open burners, "french" tops, Equi-Therm hot tops, Spectro-Heat hot tops, griddle with valve or thermostat controls, grooved griddle, and char-broiler.

Heavy-Duty "FDO" oven thermostat with range of 150° F - 500° F (66° C - 260° C).

"Cool-Touch" oven door handle for safety.

Large, 40K oven with porcelain enameled top, bottom, back liner, embossed sides, and door liner. Nickel-plated oven rack and removable rack guides for easy cleaning.

Front of range accessibility to all major components, adjustments, and service data.

The Heavy-Duty "FDO" oven thermostat delivers accurate, controlled performance for even baking and outstanding low-range control for better roasting

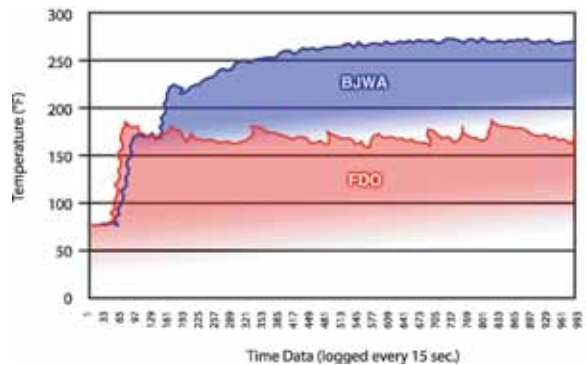



At the heart of every Master Series Range is the Starfire Burner



The unique Garland Starfire burner is the standard by which other burners are measured, and it outperforms higher rated ring burners in precision, productivity, and fuel efficiency. Its innovative design produces the most effective heat impingement pattern in the industry. This means less energy is used to transfer more heat.

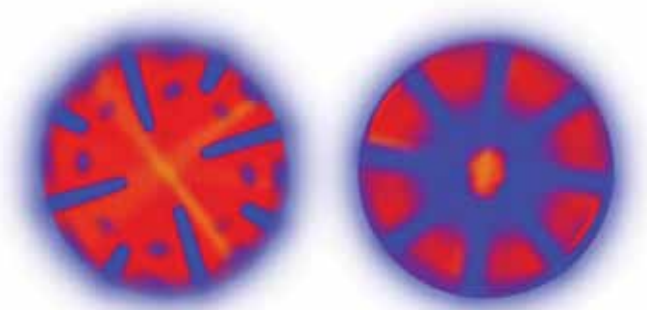

Starfire

Competition

This digital enhancement of actual laboratory scorch patterns illustrates Starfire's efficient, even heat distribution, versus a conventional ring burner.





Master Series Broilers

The Essence of Broiling

For the quality a great steak or chop deserves with a consistently produced juicy, succulent flavour, texture and appearance, only infra-red broiling is good enough. Invisible, infra-red rays create super heated energy that quickly sears the outside of the meat, sealing in natural juices, and leaving the interior at just the perfect degree of doneness. But as new age menus evolve, the essence of delicious broiled food has grown to include poultry, seafood, and even vegetables, and requires flexibility and control.



Large-capacity grease containers outside the heat zone of each broiling chamber reduces splatters or smoking due to trapped grease when your operation is running at full capacity and keeps clean up safe and simple.

New rack handle design and placement ensures the handle is cool-to-the-touch enhancing ease of use and operator safety.

Redesigned, filtered combustion airflow produces a cleaner burn, using less fuel. Maintenance time is reduced dramatically, while productivity and reliability increase.



Powerful performance for high volume kitchens

Master Series charbroilers and salamanders have been designed for quick and efficient cooking operations suited for both production line and à la carte broiling. Flexibility has been built in from the optional mounts, to the grill, to the fully adjustable grates that enable you to broil a wider variety of foods than ever before.

Reliable flexibility

- Overfired broilers deliver potent heat and are offered with your choice of infrared or ceramic heating systems.
- For added convenience and flexibility, salamanders come with dual controls, located out of the "hot zone."
- Salamanders are available for range mount, wall mount or with an optional leg kit for countertop operation.
- A full selection of cheesemelters is also available.
- Choose between the optional diamond pattern for cooking delicate products or half round broad brand for other products.

Efficient convenience

- Finishing ovens are efficiently housed over burners to capture the lost heat.
- Standard durable stainless steel front with double-access doors for convenient access. Large chrome-plated, spring-loaded grids make loading and cleaning simple.

High-performance Infra-Red Broilers

Infra-red broilers heat instantly (broiling within 2 minutes), and burn very efficiently. When compared to conventional broilers, studies show that fuel costs are reduced by up to 50%.

Thermal imaging demonstrates that despite intense, infra-red broiling power, the outer surfaces of the M110XM stay cool and safe.

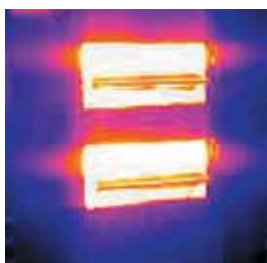

Branding options available
- diamond pattern for cooking delicate products or half round broad brand for other products.



Master Series Fryers

Quality, consistent results time and time again

High performance fryers with instant temperature recovery provides your customers with less greasy, better-tasting products. The Master Series fryers are designed for high-volume use and quickly drive off water and steam to give fried foods a desired texture and enhanced appearance. Better-tasting, consistent results and increased shortening life are the Master Series advantages.



M35SS shown with optional casters & 17" backguard

Precision results

- The centerline thermostat is located in the center of the cooking area and monitors oil temperature in precise 1 degree increments.
- Multiple burner orifices with ceramic targets produce even heat, and Garland offers a life-time warranty on the fryer tank.

Extended life

- Deep "cold zones" allow breathing and small food particles to settle without continuing to fry which extends shortening life.
- Open vat design is easy to clean, and a clean vat reduces flavour transfer from food to food and extends oil life.



We've Mastered Convenience and Safety

So that all you have to do is cook.

Easy to clean

- **Stays cleaner, longer** – Tubular high shelves allow heat and grease-laden vapors to escape.
- **Safe wipe-downs** – Smooth, finished surfaces are free from welds, screwheads, and fasteners, for fast and safe wipe-downs after use.
- **Easy cleaning between units** – We've also eliminated double legs between units so it's more convenient to clean.



Observed Creativity

- **Plating made easier** – The 7 1/2"-deep plate rail provides a smooth, level, and seam-free working area and efficient use of valuable prep time.
- **Clean, contemporary visual lines** – The design of the recessed knobs and controls compliments any kitchen while also providing easy access and reducing the risk of accidental damage.
- **Various range-top configurations** – By increasing flexibility, you can now choose to sauté on the front and use the back for bain-marie or simmering.
- **Effective use of available space** – All Master Series components can be used in single, multi-unit, and full battery configurations in sizes down to 12", to help you make the most of available kitchen space.



Considered Safety

- **International safety ratings** – The Master Series is a world-class cooking system that meets international safety ratings with optional Sentry safety protection for all open burners.
- **Monitored and controlled** – Hi/Low valves monitor and control the lowest heat setting, preventing burners from going out under griddles.
- **"Cool to the touch"** – All handles have this feature and salamander controls are located out of the "hot zone," making the Master Series safer for you to use.
- **Easy-to-grab door handles** – Handles are finished with solid ends to reduce the chance of slippage from debris buildup.

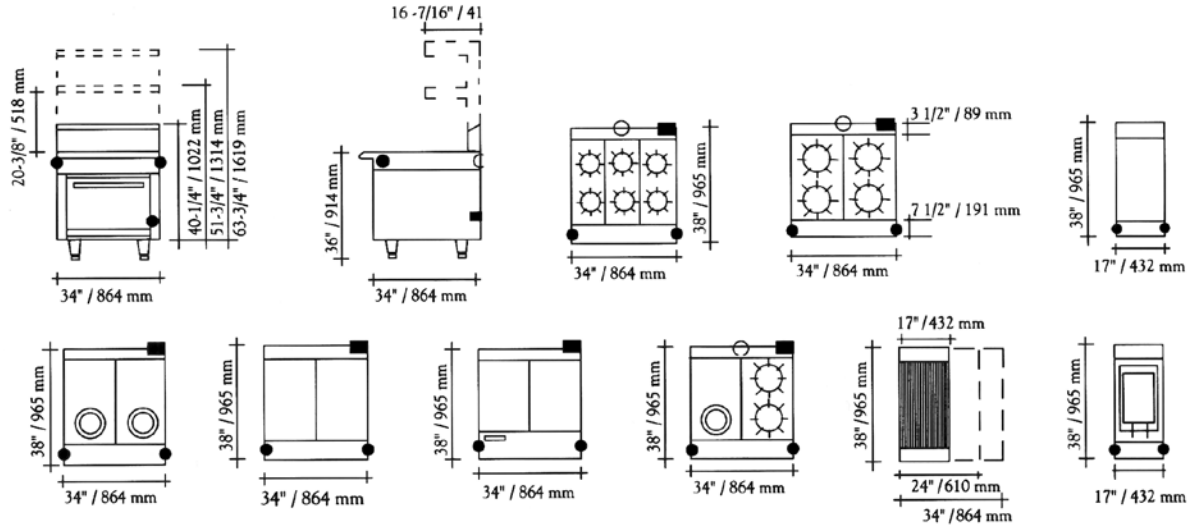

Model	Description	R-Range		S-Storage		T-Modular Top	
		BTU Rating	Weight LBS/KG	BTU Rating	Weight LBS/KG	BTU Rating	Weight LBS/KG
M MST*							
• • 43	Six (6) Open Burners	184,000	440/200	144,000	340/155	144,000	250/114
• • 44	Four (4) Open Burners	180,000	440/200	140,000	340/155	140,000	250/114
• • 45	Two (2) Spectro-Heat Sections	130,000	510/232	90,000	410/186	90,000	320/145
• • 46	Two (2) Equa-Therm Sections	130,000	450/205	90,000	350/159	90,000	260/118
• • 47	One (1) Griddle Top-34" /864 mm	139,000	600/273	99,000	500/227	99,000	410/186
• • 54	Two (2) Open Burners-One (1) Spectro-Heat Top	155,000	510/232	115,000	410/186	115,000	305/136
• • 35F	Fryers	-	-	110,000	220/100	-	-
• • 17B	Charbroiler-17"/432-mm wide	-	-	45,000	235/107	-	-
• • 24B	Charbroiler-24"/610-mm wide	-	-	60,000	330/150	-	-
• • 34B	Charbroiler-34"/864-mm wide	-	-	90,000	510/231	-	-
• • 45	Two (2) Open Burners-17"/432-mm wide	-	-	70,000	200/93	70,000	120/55
• • 55	Spectro-Heat Section-17"/432-mm wide	-	-	45,000	250/114	45,000	170/77
• • 65	Equa-Therm Section-17"/432-mm wide	-	-	30,000	210/95	30,000	130/59
• • 75	Griddle Top-17"/432-mm wide	-	-	33,000	270/123	-	-
• • SR-16	Salamander/Broiler	40,000	-	-	210/95	-	-

Convection Oven Base-Deduct 5,00 from total BTU's.

Note: Other model/options are available. See your rep for details. Specs and designs are subject to change without notice.
 *Master Sentry Series -Total Sentry Flame Failure Protection. CE approval on MST items only.



SOLUTIONS

Garland provides many of the operational solutions from Manitowoc Foodservice, a global company dedicated to bringing value to foodservice operators by equipping them with highly individualized real-world answers that enhance menus, service, profits and efficiency.



FINANCE

Manitowoc Foodservice offers low-rate, fast approval financing on all our leading brands through Manitowoc Finance. Preserve capital, simplify budgeting and get the equipment you need, today.



SERVICE

Garland products are backed nationwide by STAR Service. This network of certified service agents provides fast response with factory-trained experts to assure your equipment will be fixed right the first time. STAR service agents guarantee their work and use genuine OEM parts for best equipment performance and longer life.

To learn how Manitowoc Foodservice and its leading brands can equip you, visit our global web site at www.manitowocfoodservice.com then find the regional or local resources available to you.

