

# MERCURY

## CHAR BROILERS



Mercury Gas Range answers the needs of modern, busy catering establishments for reliable, well built equipment that offers flexibility, performance, style and value for money. Mercury equipment has been designed with safety, ease of operation and performance as paramount. Mercury has a stylish and robust modular design, constructed of high quality brushed stainless steel, large “cool to touch” dials, large heavy duty adjustable feet and easy to clean and remove accessories.

The Mercury Broiler is available in Radiant or Lava Rock configurations and ideal for cooking steaks, chops, hamburgers and seafood. The Mercury Broiler is a sturdy reliable option for the increasing demand of char grilled food.

## Product Features

- Stainless steel construction and finish
- Heavy duty cast iron grilling grates
- Manually controlled, independent cooking zones
- Large, robust dial controls
- Heavy duty cast radiant as standard
- Stainless steel burners
- Burner valves
- Removable full width waste tray
- Heavy duty adjustable feet
- 3/4” rear gas connection
- Flame failure as standard
- Full size back flue guard
- Supplied on enclosed cupboard stand

## Gas Char Broilers



# Gas Char Broilers

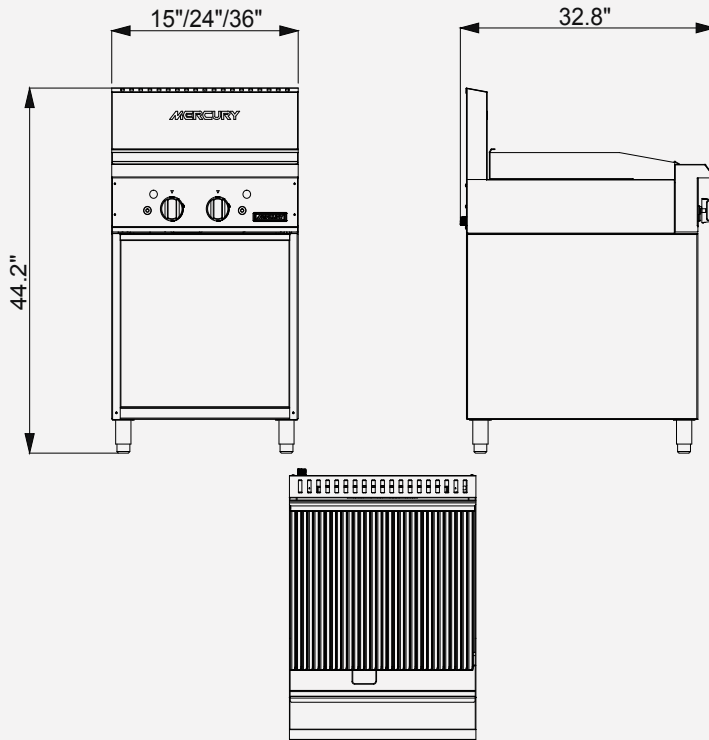

**MERCURY**

Product Code	'U' Shape Burners	Capacity/ Coking Area	MJ			
				Width	Depth	Height
<b>MCN-15-FR</b>	1	377 x 510 mm	32.5	381	836	1124
<b>MCN-24-FR</b>	2	610 x 510 mm	65	610	836	1124
<b>MCN-36-FR</b>	3	915 x 510 mm	97.5	915	836	1124

- Gas connection  
3/4 male, all units supplied with Natural and LP gas regulator
- Installation: allow 100mm for gas regulator at rear of unit
- Feet 28mm adjustable
- Gross weight:  
MCN-15-FR: 91 kg  
MCN-24-FR: 145 kg  
MCN-36-FR: 209 kg

The dimensions given are reference dimensions only. Due to a continuous program of product improvement, Middleby Food Service Equipment reserves the right to make product changes without notice.

This document contains information that is confidential and proprietary to Middleby Food Service Equipment and shall not be reproduced or transferred to other documents or disclosed to others or used for any purpose other than that for which it was obtained without the expressed written consent of Middleby Food Service Equipment.

 **MIDDLEBY GOLDSTEIN**