

PREMIER 1635

BENCHTOP VACUUM PACKER WITH GAS-FLUSH & SENSOR CONTROL

The PureVac Premier 1635 is a powerful benchtop vacuum packaging machine. Made in Holland, the machines combine tightly crafted and functional design with ease of use and operation. The Premier range has extra functions such as sensor control, soft-air and gas-flush as standard, making these machines the most advanced and intuitive on the market.

Vacuum packing with PureVac will improve your production and storage functions, save you money and contribute to your food safety and HACCP guidelines.

With a 16m³/h capacity Busch pump and a 350mm sealing bar, the PureVac Premier 1635 will vacuum pack a large range of food products in any medium-to-large sized business.



STANDARD FEATURES

- Stainless steel housing and deep-drawn vacuum chamber for optimal hygiene
- Removable wireless sealing bar
- Insert plates for adjusting vacuum chamber height
- Vacuum - Optimal final vacuum 99.80% (2 mbar)
- Gas-flush - Injecting food-gas for product protection and longer shelf life
- Soft-air - Controlled ventilation for protection of product and packaging
- 2 x 3.5mm seal wires for an extra-strong double seal
- Sensor Control - Set percentage pressure for vacuum and gas functions for accurate and constant packaging results / Automatic programming / 10 default programs / Vacuum plus time
- STOP button for partial/full cycle interruption
- Digital maintenance program for pump / Operating hours counter / Service indicator programs / Sleeper function etc
- Service kit for user maintenance



Busch vacuum pumps, world leaders in vacuum pump technology



Two years parts and labour warranty

SPECIFICATIONS ARE SUBJECT TO CHANGE WITHOUT NOTICE.

From the world of Comcater!

National Head Office
156 Swann Drive
Derrimut VIC 3030
Tel: +61 3 8369 4600
Fax: +61 3 8369 4695

Melbourne
96-100 Tope Street,
South Melbourne VIC 3205
Tel: +61 3 8369 4600
Fax: +61 2 8699 1299

Sydney
20/4 Avenue of the Americas
Newington, NSW 2127
Tel: +61 2 9748 3000
Fax: +61 2 9 648 4762

Brisbane
1/62 Borthwick Avenue
Murarrie QLD 4172
Tel: +61 7 3399 3122
Fax: +61 7 3399 5311

PREMIER 1635

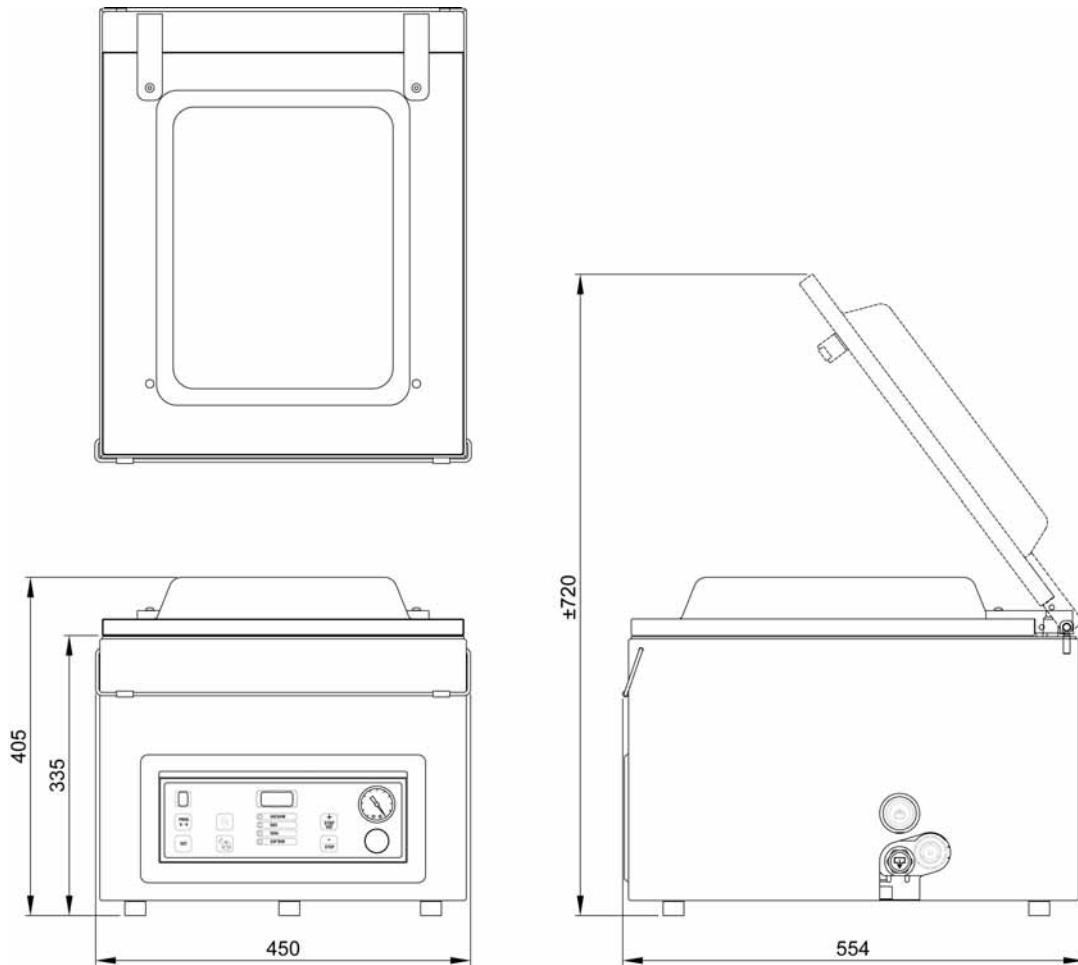

DIMENSIONS

External: 450W x 554D x 405H mm

Chamber: 350W x 370D x 150H mm

Sealing Bar: 350mm

Weight: 49Kg

OPTIONS

- Inclined insert plate for packing liquid products
- Trolleys with 3 shelves and lockable castors

TECHNICAL DATA

Power Supply: 240V, 50Hz, Single Phase

Power Output: 0.55kW

Capacity pump: 16 m³/h

Machine cycle: 15-30 seconds

SPECIFICATIONS ARE SUBJECT TO CHANGE WITHOUT NOTICE.