

The Australian owned and designed* Trueheat RC Series of Gas Cooking Equipment has been developed for the restaurant and cafe market with a high quality finish, designed to fulfill the busy demands within a commercial kitchen.

Powerful 24MJ/hr open burners with individual standing pilots included. 100% Flame failure controls included as standard. Matt finish premium lead cast iron trivets radiant heat and design makes it easy to move pots around the surface.

16mm thick steel griddle plate with 16.5MJ/hr burner per 300mm section.

Static oven with two oven racks fit to removable vertical rack guides which provide 3 rack heights. Oven racks are fabricated from 304 stainless steel. Interior oven panels are coated with black vitreous enamel for ease of cleaning.

Note: Griddle is convertible to left hand side. Additional charges apply.

DIMENSIONS & WEIGHT

External Dimension: 900W x 830D x 1135H mm
Net Weight: 209kg
Working height : 910mm
Oven Interior : 660W x 540D x 320H mm
Combustible wall clearance: Side: 150mm, Rear: 150mm

TECHNICAL DATA

Gas Type: Natural or Propane			
Total Output(MJ/hr):	Natural Gas 117	Propane Gas 114	
Burner Ratings (MJ/hr):	Natural Gas	Propane Gas	Ignition Type
Open Burner (MJ/hr):	24	24	Manual
Griddle 300mm (MJ/hr):	16.5	16.5	Piezo
Oven (MJ/hr):	36	33	Piezo
Gas Connection: 3/4" Female			
AGA approval number: AGA 6652 G			

SHIPPING DATA

Shipping Weight: 237kg
Shipping Dimensions: 900W x 803D x 983H mm

OPTIONAL ACCESSORIES

Part Number:	Description:
GF-CSTRB	Front Castor Swivel with brake suits RCR models only
GF-CSTR	Rear Castor without brake suits RCR models only
432018-900HK	900mm 3/4 flexible gas hose with quick connect fittings and restraint
432018-1200HK	1200mm 3/4 flexible gas hose with quick connect fittings and restraint

SPECIFICATIONS ARE SUBJECT TO CHANGE WITHOUT NOTICE.

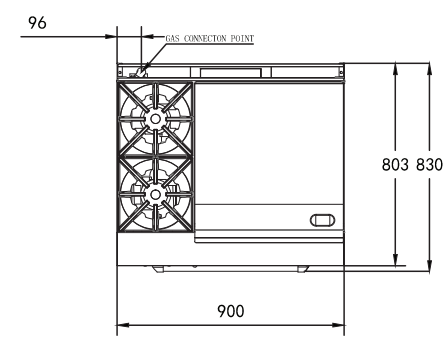
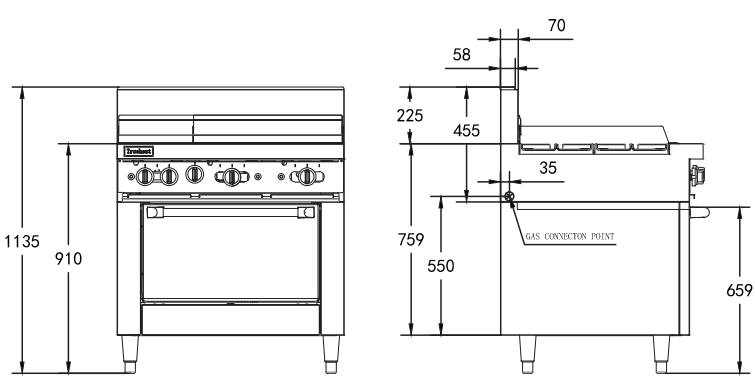

*manufactured in China