

# ALFA43XE1HDS

**MULTI FUNCTION** HUMIDIFIED CONVECTION OVEN - 1.5 AMP

4 Trays 435x320mm



## GUARANTEED COOKING PERFORMANCE

Smeg catering products draw on the experience of approximately 40 years in the Foodservice industry. The ovens are built with the highest quality materials, making them particularly tough and strong.

## VERSATILITY

The complete Smeg Professional catalogue offers a range of ovens for all needs and environments, fulfilling any requirement in the most efficient and high-performing way.

### PRODUCT FEATURES

- Multifunction Electric Oven, 9 available functions
- **Adjustable fan speed**
- Compact and functional design, robust stainless steel construction
- Enamelled oven cavity
- Electronic touch controls, easy to use, simple and reliable
- **Excellent baking uniformity across all trays, perfect heat distribution in all conditions of use**
- Excellent internal visibility, due to the large glass and powerful inner light
- Double glass door, with internal glass removable for cleaning
- 4 flat aluminium trays (model 3820) included
- **15A plug**
- Dimensions (mm) (WxDxH): 602x584x537
- **24 months parts and labour warranty**

### INCLUDES 4 X FLAT ALUMINIUM TRAYS



### OPTIONAL ACCESSORIES

- TVL40 - Stainless steel stand
- 3820 - Aluminized steel tray
- 3729 - Chrome grid
- 3780 - Non-stick tray
- 3735 - Undulated chrome grid
- 3755 - Flat aluminium tray with holes

# ALFA43XE1HDS

**MULTI FUNCTION** HUMIDIFIED CONVECTION OVEN - 1.5 AMP

4 Trays 435x320mm

## TECHNICAL SPECIFICATIONS

Dimensions (mm) (WxDxH)	602x584x537
Trays (mm)	435x320
Tray capacity	4
Distance between trays (mm)	80
Control type	Electronic
Water Connection	Yes
Door/hood structure	Stainless steel
Temperature range (°C)	30 - 270°C
Timer	1 min - 99 hours + infinite
Power rating & electrical connection	230V~/13A/3.0kW/50-60Hz
Net weight	38.1kg

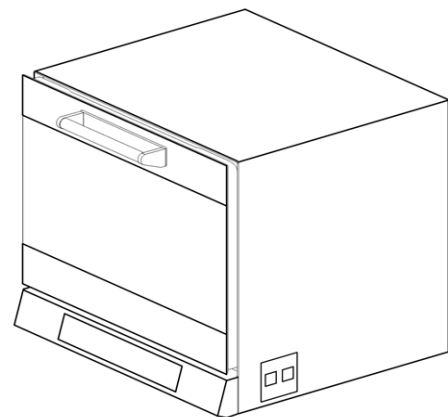
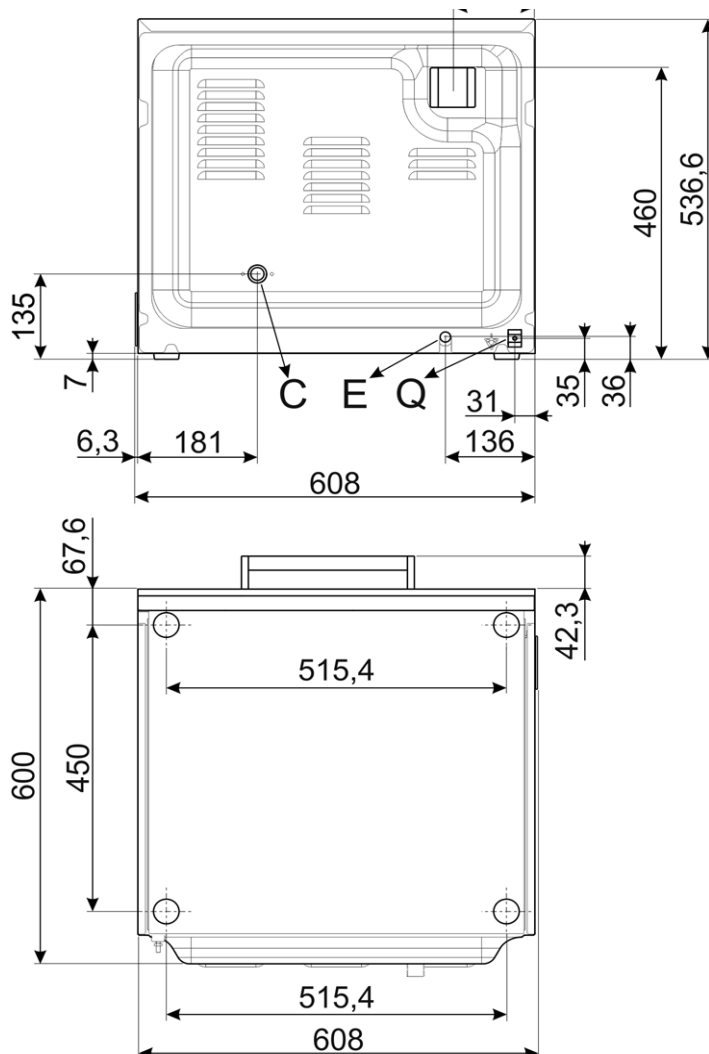

Q	MORSETTO EQUIPOTENZIALE EARTH TERMINAL
E	CAVO ALIMENTAZIONE ELETTRICA ELECTRICITY SUPPLY CABLE
C	TUBO DI CARICO (solo su alcuni modelli) FILLER HOSE (on some models only)



UNI EN ISO 9001  
9130-Smeg

UNI EN ISO 14001  
9191-SME2

OHSAS 18001  
9192-SME3