

MZN213 | Zanotti ZN Range Slide-In Refrigerated Chiller Systems

Refrigeration Systems

MZN213

ZANOTTI ZN RANGE SLIDE-IN REFRIGERATED CHILLER SYSTEMS

Condensate evaporation system eliminates the need for drainage

Simple plug-in operation reduces installation cost & time

Reliable L'Unite Hermetique compressor ensures unit longevity

Condenser cover included

Pre-wired for:

- Internal light
- Door switch
- Door heaters (Low temp units)

High 45°C tropical ambient temperature rating for reliability in Australian conditions

Advanced digital controllers (full function)

Three-pin plug with 2m lead for instant power connection



Internal light included



Drainage may be required in extreme ambient conditions or when storing high-water content produce



Digital Controller



MZN213 | Zanotti ZN Range Slide-In Refrigerated Chiller Systems

Refrigeration Systems

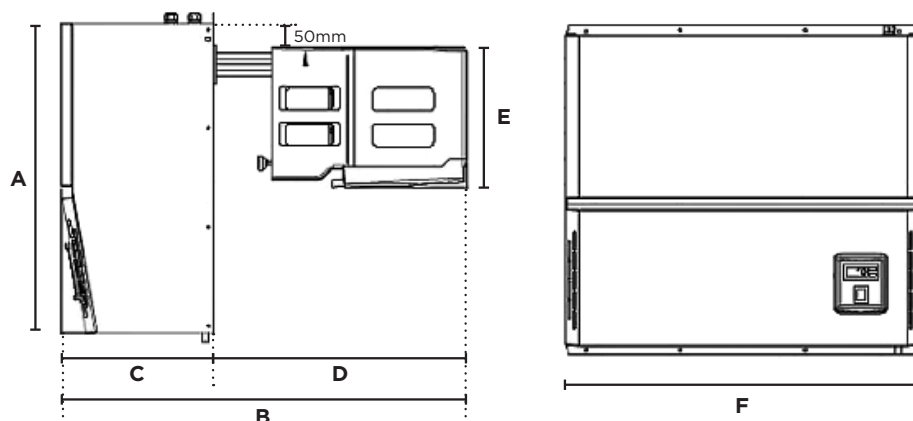

DIMENSIONS

	External (mm)
A	660
B	865
C	325
D	540
E	300
F	760

Mounting Scheme

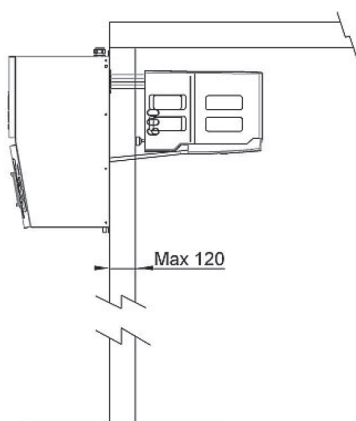

Straddle-wall application

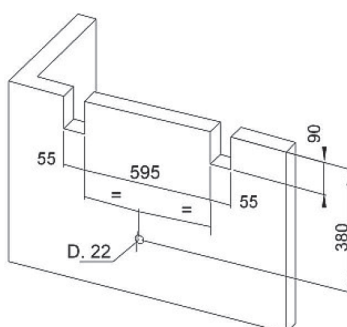

Ceiling minimum height

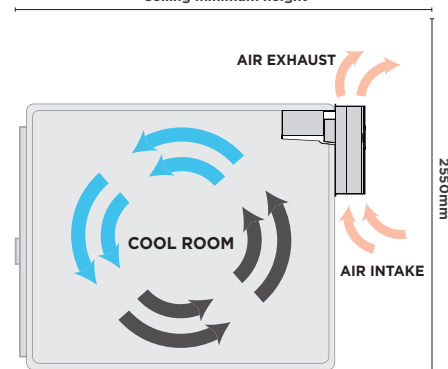

Sliding in from the side, this slim system utilises a vertical air path to minimise clearance requirements

SPECIFICATIONS

Part Number	3835213
Refrigeration Capacity	3006W
Temp. Range (°C)	-5 to +10°C
Max. Ambient Temp. (°C)	45°C
Run/Full-Load (Amps)	8.68/11.86A
Temp. Display	Digital
Internal Light	Yes
Gross Weight (kg)	66kg
Refrigerant	R404a
Power Supply	15A
Defrost Type	Electronic
Type of Control	Digital
Internal Light	Pre-Wired
Heated Door Trim	No
Drainage Required	No
Warranty	1 Year, Parts only
Warranty Service	Bromic Extra Care

POWER DATA

Tc °C	Ta °C	P watt	P Kcal/h	V100 m³	V80 m³	V60 m³
	20	3852	3313	47	43	39
	25	3714	3194	45	41	37
10	30	3551	3054	42	38	35
	35	3354	2884	39	35	32
	40	3110	2675	35	32	29
	45	2807	2414	31	28	26
	20	3452	2969	41	37	34
	25	3215	2765	37	34	31
5	30	3006	2585	34	31	28
	35	2810	2417	31	28	26
	40	2612	2246	28	25	23
	45	2398	2062	25	23	21
	20	3068	2638	35	32	29
	25	2820	2425	31	28	26
0	30	2637	2268	28	25	23
	35	2481	2134	26	24	22
	40	2312	1988	23	21	19
	45	2092	1799	20	18	17
	20	2669	2295	29	26	24
	25	2469	2123	26	24	22
-5	30	2296	1975	23	21	19
	35	2134	1835	21	19	17
	40	1964	1689	18	16	15
	45	1768	1520	16	15	13

* Medium temp rated at 5°C internal temperature and 30°C ambient temperature.

BROMIC PTY Ltd reserve the right to alter specifications without notice.