



SW500 Smartwash Undercounter Warewasher



The New Smartwash Range of undercounter warewasher is the first attractive, intelligent, one touch warewashing system in Australia that offers incredibly sustainable results in water and energy consumption. This professional warewasher offers the first one touch control panel with digital wash and rinse temperature displays for easy HACCP recording for accurate food safety reporting. These machines are sleek and compact because we know space is of the essence and presentation is key. Only Smartwash offers you a warewasher with one touch control, drain pump fitted as standard, a self cleaning cycle and 4 wash cycle options, offering you an economical and sustainable solution for your business.

SW500 standard features and benefits

- Up to 500 x 350mm plates per hour, Up to 2000 glasses per hour
- User friendly TOUCH control panel with digital wash and rinse temperature displays for easy HACCP recording
- Water saving - uses only 2.5 litres per cycle
- Four wash cycles of 60, 90 & 180 seconds + special (time variable wash cycle chosen by operator - time limit 12 min)
- Generous 365mm door height opening will take the largest of plates, pizza trays, kitchen utensils and tall stem glassware
- Extra special 6 minute "scrub cycle" for more soiled product
- Self cleaning cycle, easily removable spray arms & filters together with a pressed wash tank
- Double skinned door drastically reduces heat & sound emissions
- Self-Diagnostic system for accurate fault finding & reduced ownership costs
- Thermostop Function to ensure set rinse temperature is achieved



60 sec



90 sec



180 sec



+ 1 special



Standard accessories

- plate and glass rack 500 x 500 mm
- cutlery container



Please note, due to ongoing product development and improvement, we reserve the right to change product design and specification at any time without notice.



1800 013 123 | +61 2 9604 7333
sales@middleby.com.au
middleby.com.au

VIC - TAS - 47 Stubbs Street, Kensington VIC 3031
QLD - U12, 210 Queensport Rd Nth, Murarrie QLD 4172
WA - U2, 9 Meares Way, Canning Vale WA 6155

HEAD OFFICE
AND MANUFACTURING PLANT
211-217 Woodpark Road, Smithfield NSW 2164

vi_2024



SW500 Smartwash Undercounter Warewasher

- A. Drain connection \varnothing 25mm M, 2 m flexible hose
- B. Water connection G 3/4" M, 2 m S/S braided hose
- C. Electrical connection 240V, 15A plug, 2 m cable

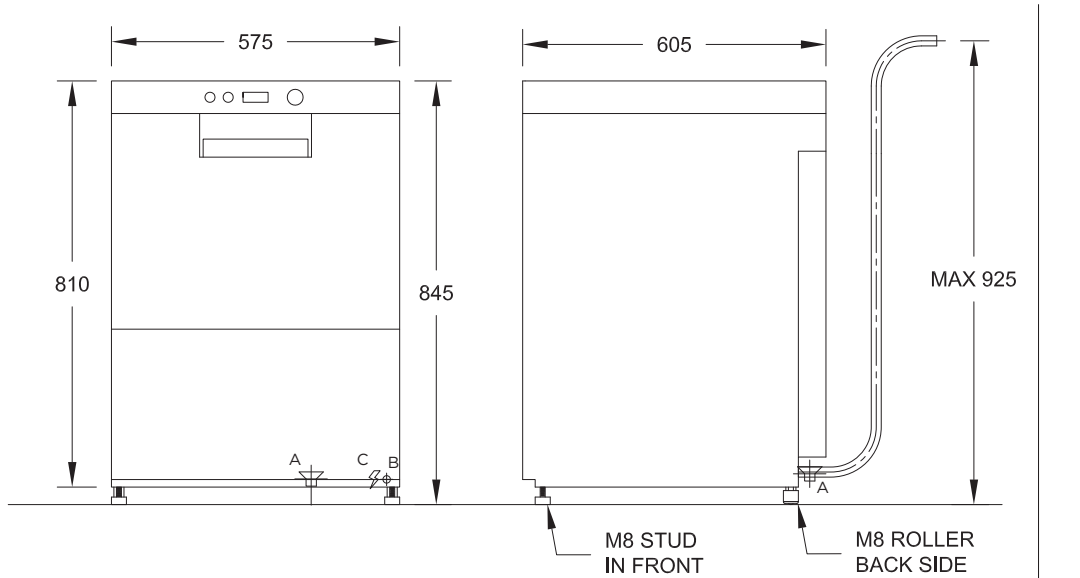

SW500 SPECIFICATIONS



DIMENSIONS (WxDxH)	575 x 605 x 820 mm	WASH / RINSE ARMS	Hydrodynamic Parallel
DOOR ENTRY	365 mm	CONTROL PANEL	Advanced Electronic Soft-Pad
RACK SIZE (WxD)	500 x 500 mm	SELF CLEANING CYCLE	YES
ELECTRIC CONNECTION	240V / 50Hz / 1 Phase 15A Plug / 2 m	TEMPERATURE GAUGE	Fitted
WATER CONNECTION	3/4" x 2 m Braided Hose	SELF-DIAGNOSTIC SYSTEM	Fitted
DRAIN CONNECTION	25 mm x 2.5 m ID Hose	RINSE-AID & DETERGENT PUMP	Fitted
RATING	3.2 kW	DRAIN PUMP	Fitted
WATER SUPPLY	65°C / 2-4 bar (28-58 psi)	2 X REAR STAINLESS STEEL CASTORS	Fitted
WASH CYCLE	60 / 90 / 180 sec + special	THERMOSTOP, TANK STRAINERS	Fitted
WATER CONSUMPTION	Approx. 2.5L per cycle	WEIGHT	56 Kg
MEAL SERVICE	30 - 60 pax		
DOOR CONSTRUCTION	Double-Skinned		

Please note, due to ongoing product development and improvement, we reserve the right to change product design and specification at any time without notice.



1800 013 123 | +61 2 9604 7333
sales@middleby.com.au
middleby.com.au

VIC - TAS - 47 Stubbs Street, Kensington VIC 3031
QLD - U12, 210 Queensport Rd Nth, Murarrie QLD 4172
WA - U2, 9 Meares Way, Canning Vale WA 6155

HEAD OFFICE AND MANUFACTURING PLANT
211-217 Woodpark Road, Smithfield NSW 2164

v1_2024