

WARRANTY 3 YEARS
PARTS & LABOUR



Turbo air

NSW & VIC Rebate Eligible

CHEF BASE

Fridge

TCB18-4-N / TCB18-4(HC)

FEATURES / BENEFITS

Digital temperature control & monitor system

Keep food products safe by maintaining constant temperatures. External digital display allows for easy monitoring.

Hydrocarbon(HC) refrigerants (R-290)

With innovative and eco-friendly technology, Turbo Air brings you hydrocarbon refrigerators designed to meet DOE's Energy Conservation Standards in 2017 and to use EPA's SNAP Program approved HC refrigerants. Hydrocarbon refrigerants do not deplete the ozone layer and have very low affect to global warming (ODP-0, GWP-3).

Side mount compressor unit

With compressors positioned on the side of the unit, our refrigerators can now be serviced without being moved. Our innovative, front breathing feature also allows this model to be highly efficient in narrow spaces.

Exterior & interior of the cabinet

The Turbo Air Kseries boasts a stainless steel exterior (galvanized steel back and bottom). Interior is stainless steel floor with AL sides, back and AL door liners. It guarantees the utmost in cleanliness and long product life. The K-series adds a touch of style to the most refined setting.

Extra High-density polyurethane insulation

The entire cabinet structure and solid doors are foamed-in-place using high density, CFC free polyurethane insulation.

Hot gas condensate system

Through Turbo Air's creative innovation, the condensate system surfaces have been specially treated to resist corrosion. This not only increases

efficiency without the risk of refrigerant leakage from corrosion, but also

Refrigerator holds 1°C ~ 8°C for the best in food preservation

NATURAL
Refrigerant



- GN PANS not included

Standard features

- Anti-corrosion coated evaporator
- Self-contained system

Optional features

- 125mm castors fitted
- 180mm, 105mm, 80mm castors optional
- Adjustable legs 100-155mm

REFRIGERATOR MANUFACTURER
Turbo air

■ WARRANTY: 3 Year Parts and Labour Warranty

CHEF BASE

Fridge
TCB18-4-N / TCB18-4(HC)

Model	TCB18-4-N
Refrigerant	R290
POWER INPUT(W)	325W
COMP (HP)	1/2HP
Energy consumption KW/24H	2.76
AMPS(A)	2.8
Capacity (ℓ)	124
Product Dimension W (mm)	1800
Product Dimension D (mm)	700
Product Dimension H (mm)	585
Weight (Kg)	140
Stainless steel	SUS 439
Applied castors	Leg
Max GN Pan depth	140mm
GN Pan	Not include
Door lock	no
Adjustable Shelves	N/A
LED light	No
Temperature range	1~7°C
Ambient temperature	30°C
Drainage / Forced Evaporation Type	Yes
Temperature control type	Digital control
Cooling type	FAN COOLING
Glass Type (Low-e / Heater / How many layer of the glass)	N/A
Features	Energy efficient
<small>Design and specifications subject to change without notice. Actual Shipping weight may differ due to extra packing materials for product protection.</small>	

PLAN VIEW

(unit : mm)

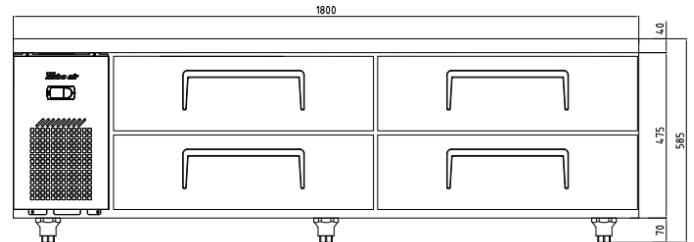
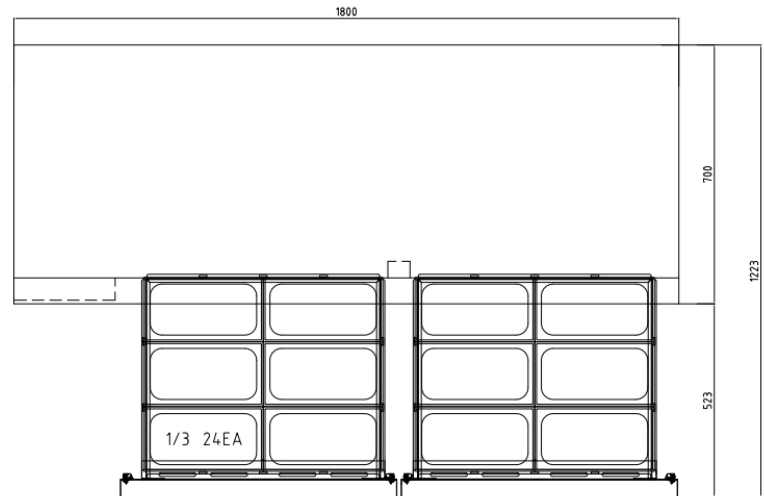

TCB18-4

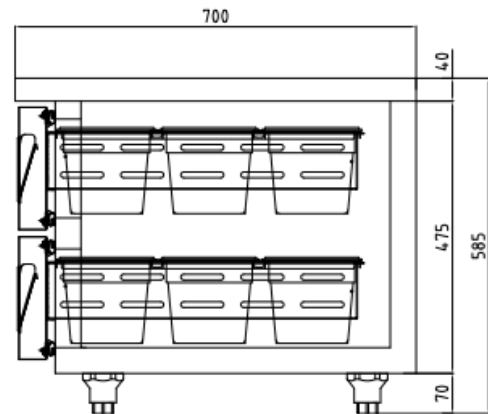

TCB-SERIES
SIDE VIEW

WARRANTY 3 YEARS
PARTS & LABOUR



Turbo air

email : TA.admin@turboairinc.com.au

AUSTRALIA BRANCH

TURBO AIR PTY LTD
www.turboairinc.com.au
 1st Floor, Building E
 10 Highgate St, Auburn
 NSW 2144 Australia
 T. 02 9737 9881