

Heavy Duty Chest Freezers With S/S Lid

BD-F SERIES

BD520F/BD600F/BD750F



Efficient Cooling Performance
Utilizes environmentally friendly R290 refrigerant for a reduced carbon footprint and enhanced workplace safety.

User-Friendly Convenience
Features digital control, an interior LED light, removable baskets.

Flexible Options to Suit Your Needs
Available in single and double door models with multiple capacities (5, 6, or 8 baskets) to match your space and requirements.

Durable & Portable Design
Built with a sturdy aluminium and equipped with easy-rolling casters for flexible movement.

DETAILS

The Thermaster BD-F Series Chest Freezer boasts a range of outstanding features. The energy saving fan optimises airflow to reduce power consumption, while the quick and deep freezing function rapidly reaches core temperatures of -22°C for long term preservation.

The efficient compressor ensures stable performance with minimal energy waste, and the low noise operation makes it suitable for quiet environments. The integrated LED light illuminates and the digital temperature control allows for precise adjustments between -18°C and -22°C.





BD-F SERIES

HEAVY DUTY CHEST
FREEZERS WITH S/S LIDS

FEATURES

SMART STORAGE & OPERATION

Removable baskets for flexible storage and manual defrost for easy maintenance.

USER-FRIENDLY CONVENIENCE

Digital controls, built-in LED light, and low-noise operation for everyday ease of use.

STABLE & UNIFORM TEMPERATURE CONTROL

Advanced cooling maintains even temperatures for longer food preservation.



Lock & Key, LED lighting, AISI304 Hinge door

AISI304 Painted Steel Top Cover

Digital Controller

Castors For Easy Movement

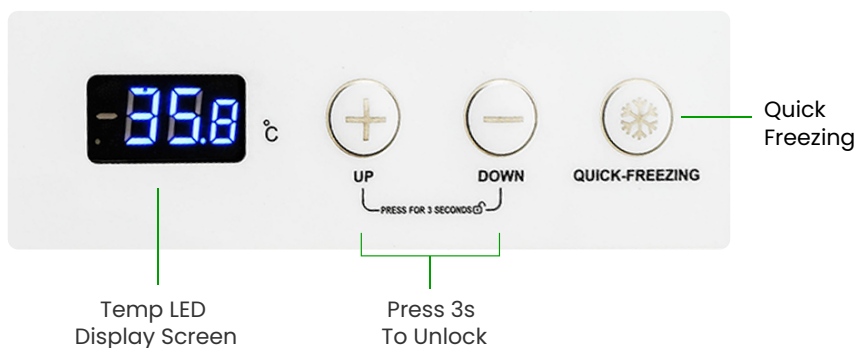

Temp LED Display Screen

Press 3s To Unlock

Quick Freezing



Removable Basket
Each basket
(570x225x170mm)

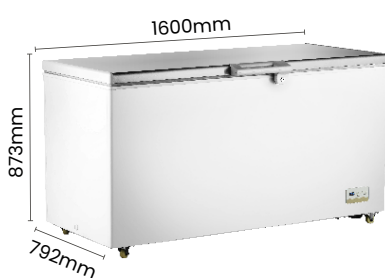

BD520F

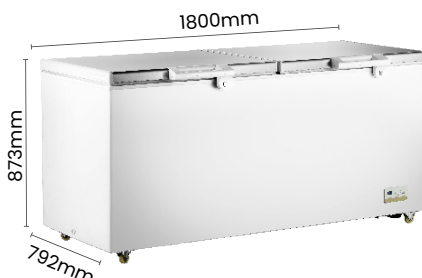

BD600F

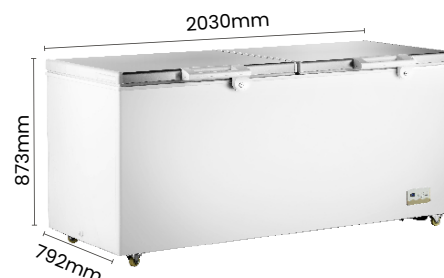

BD750F





BD-F SERIES

HEAVY DUTY CHEST
FREEZERS WITH S/S LIDS

Product Summary

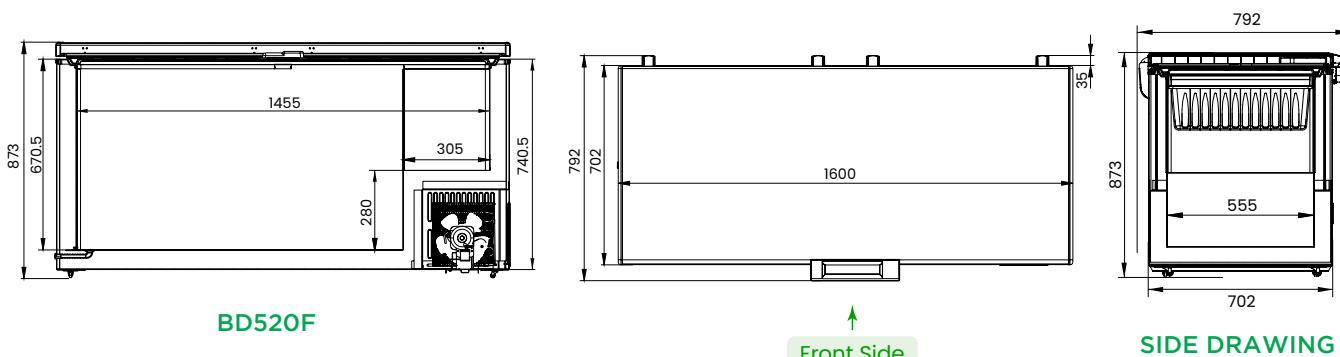

BD520F

↑
Front Side

SIDE DRAWING

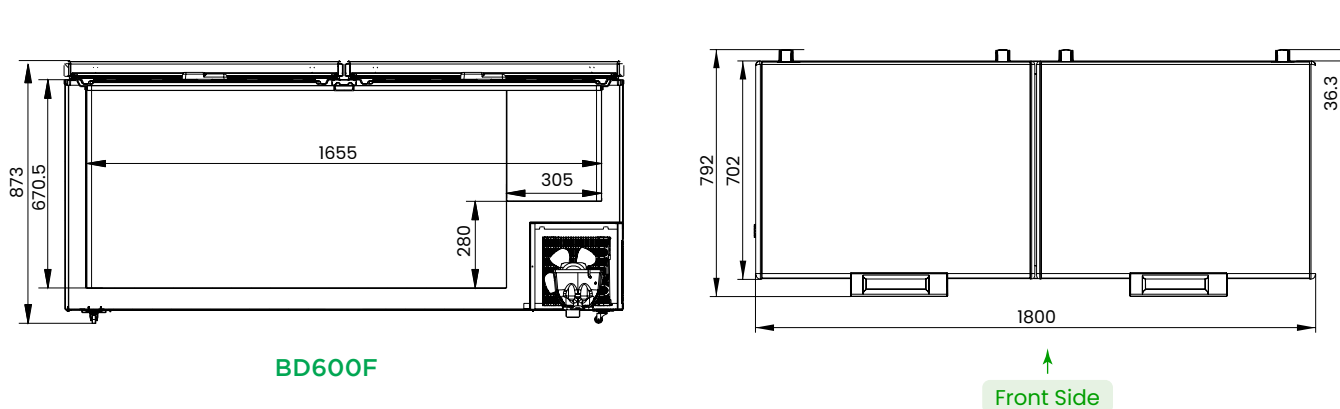

BD600F

↑
Front Side

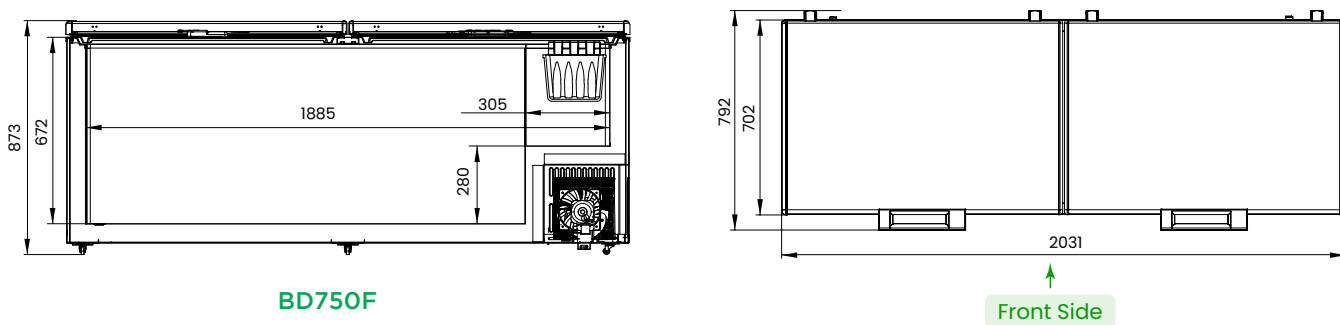

BD750F

↑
Front Side

Product Code	GEMS Star Rating	Basket	Gross Capacity (L)	Dimensions (WxDxH mm)	Weight (kg)	Temp Range (°C)	Ambient temp/RH%	Power (W/A)
BD520F	8	5	520	1600x792x873	63	-22 to -18°C	32°C 55%	240/10
BD600F	8	6	600	1800x792x873	64.5	-22 to -18°C	32°C 55%	270/10
BD750F	8	8	750	2030x792x873	77.5	-22 to -18°C	32°C 55%	270/10

To ensure we continuously offer the best possible products, we reserve the right to modify specifications without any obligation for equipment previously or subsequently sold.





BD-F SERIES

HEAVY DUTY CHEST
FREEZERS WITH S/S LIDS



Heavy Duty Chest Freezers With S/S Lid BD-F SERIES

BD520F/BD600F/BD750F



**ENERGY
RATING**
THE MORE STARS
THE MORE SAVINGS

