

# 400L Gelato/ Ice Cream Display

## SD-415P

The product features a transparent glass design for a 360° unobstructed display of gelato's vibrant colors and textures. It also includes an internal LOW-E glass design for excellent insulation and energy efficiency. The unit has compartmentalized sections for different ice cream flavors, storage functionality, and a drainage tray. The sliding glass door allows for easy ice cream replacement, while a lock and key provide security. Additionally, the product strictly adheres to food safety certification standards, including IEC/IECEE certification and an 9-star GEMS rating.



### Key Features



#### GEMS Compliant

Greenhouse and energy minimum standards



#### Static Cooling

Keeps ice cream perfectly textured and tasty.



#### 360° Unobstructed Display

Showcase the vibrant colors and texture of Gelato.



#### LOW-E Glass Design

High-efficiency insulation energy-saving anti-fog/condensation.

### Details



- With a total capacity of 45L for 9 pans, it meets various varieties and flavors of gelato.
- A wide range of containers is available, such as portion tubs, cylinders, and cakes.

Code	GEMS Star Rating	Dimensions (W x D x H mm)	Weight (kg)	Temperature Class	Max. ambient temp/RH%	Power (W/A)
SD-415P	9	1350x838x1270	123	-12°C to -15°C	30°C/55%	310/10



### Brilliant LED Lighting

Showcases items with several individually lights.



### Sliding Glass Door

Optimised slide rail design for reduced resistance Smooth movement.



### The Gelato Pans

Total 45L capacity with 9 gelato pans for various flavors.



### Fog-Proof Condensation-Proof

Maintenance-free, preserving the premium quality of ice cream.



### Leak Prevention Function

Keeps the display cabinet dry.

## Product Design Overview

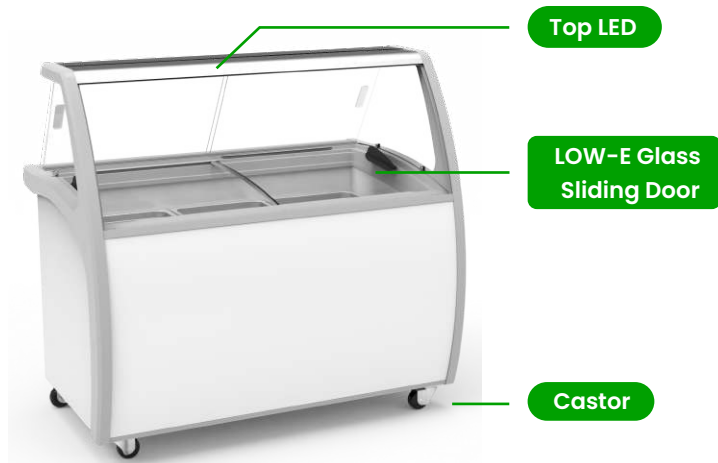

Top LED

LOW-E Glass  
Sliding Door

Castor



Inside LED

12 Gelato Pans



Fresh water connection  
for overflow valve

Scoop washing tank

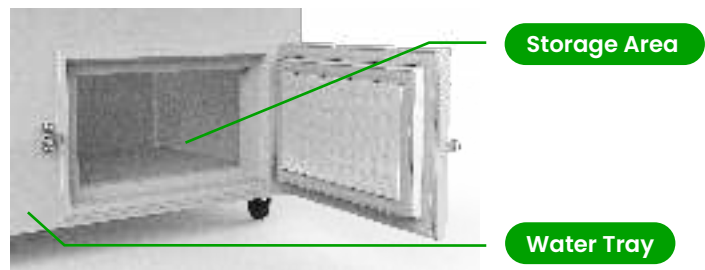

Storage Area

Water Tray



# Product Summary

The product has a transparent glass design for a 360° view of gelato's vibrant colors and textures. It includes LOW-E glass for insulation and energy efficiency. It has compartments for different ice cream flavors, storage space, and a drainage tray. The sliding glass door makes ice cream replacement easy, and it comes with a lock and key for security. It meets food safety standards, including IEC/IECEE certification and an 9-star GEMS rating.

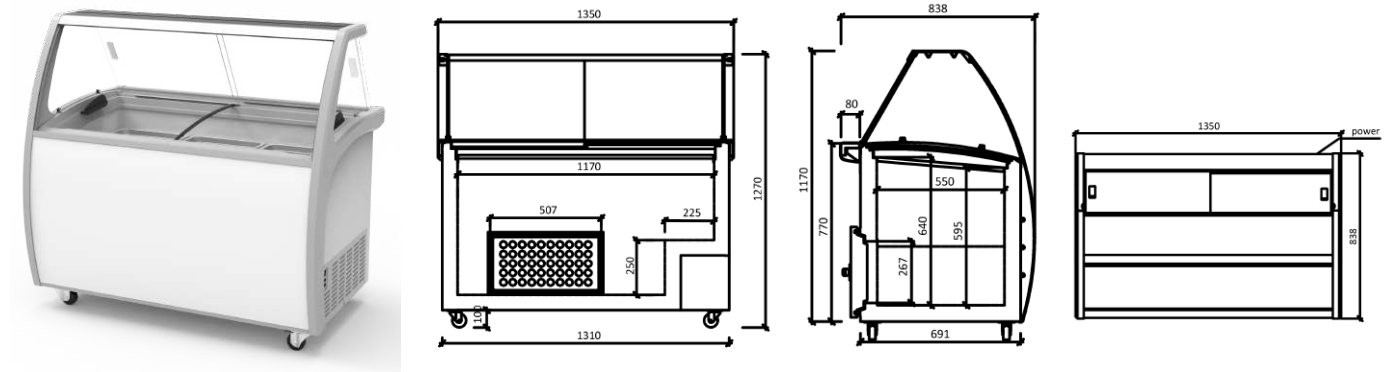

## FEATURES AND FUNCTIONALITIES

Cooling System	Static Cooling
Compressor Unit	Cubigel
Energy Efficiency	4.079 kWh/24h
Exterior & Interior of the Cabinet	Exterior Body White, Interior Body White, Pre-painted Steel.
Ergonomical Design	LED lights; Water tray 0.45L; 4 casters for easy movement; Compartmentalised design; Lock and key; Washing tank.
Durable Door Profile	LOW-E and tempering Glass sliding door.
Gelato Pan	9 Pans, 5L/pan; 304SS.
Blowing Agent	70mm, Cyclopentane.

## TECHNICAL DESCRIPTION

Power Cord	10Amp plug and lead
Power cord length	2.9m (2.2m outside cabinet)
Power Supply	240V/50Hz; 310W
Rated Current	1.5A
Evaporator Design	Galvanized Steel Tube
Compressor cooling capacity(W)	325
LED Lights	1x9.5W LED strip, upper inner liner 1x12W LED strip, underneath top plate 3x11.5W LED strips, front panel

## SAFETY & STANDARDS

IEC/IECEE CB; GEMS(Refrigerated Cabinets) Determination 2020 ; EN 16838:2016;

## PHYSICAL QUALITIES

Width (mm)	1350
Depth (mm)	838
Height (mm)	1270
Packing Width (mm)	1480
Packing Depth (mm)	1005
Packing Height (mm)	1310
Net Weight (kg)	123
Total Capacity (L)	400
Total Display Area [m <sup>2</sup> ]	0.53

## PERFORMANCE SPECIFICATION

Max. ambient temp/RH	30°C 55%
Climate Class	4
Temperature Class	-12°C to -15°C
Rated kWh/year	1488.835
Refrigerant	R290 (105g)
Energy Efficiency Index (EEI)	15.3
Star Rating / GEMS Rating	9 (4L3)

## WARRANTY

1 Year Parts and Labour



IEC 60335-1:2010+A1+A2  
IEC 60335-2-89:2019



# Customisation Options

Customised corporate solutions available upon request



# Suitable For Various Scenarios



Ice Cream Shops



Supermarkets



Restaurants



Cafes

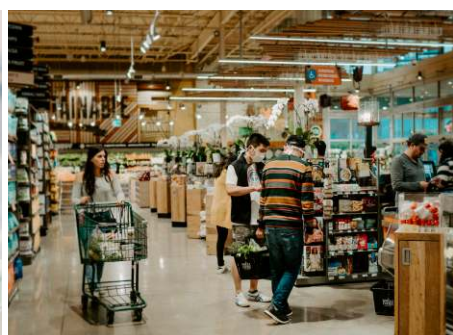

Supermarkets



Convenience Stores