

## **Twist60G, Twist90G, Twist130G, Twist160G, Twist200G, Twist250G, Twist300G Spiral Mixers**

### **Product Features**

- Fixed stainless steel bowl
- Patented breaker arm fitted
- Two speed operation
- Fitted with wire grid guard
- Bowl reverse function and automatic change from low to high speed
- Supplied on wheels with adjustable feet for added stability
- As required by safety regulations fully guarded with an inbuilt micro-switch control safety feature
- Comprehensive operation and cleaning procedure manual supplied



**TWIST60**

Sottoriva is a leading Italian manufacturer of machines and lines for the bread and pastry industries. Established in 1941, Sottoriva offers a comprehensive range of heavy duty equipment to suit from small bakeries right through to large industrial installations, all manufactured to the highest standards to ensure many years of optimal performance. The Sottoriva equipment range includes spiral, fork and double arm dough mixers, removable bowl mixers, automatic roll divider / rounders, fully automated bread roll production lines, fully automated bread production lines and a range of specialized equipment for the craft baker. World renowned for quality equipment, optimal performance and superior reliability, Sottoriva Technology can certainly provide the future for your bakery.

# Twist60G, Twist90G, Twist130G, Twist160G, Twist200G, Twist250G, Twist300G Spiral Mixers

Model	Dimensions (mm)					Weight (kg)	Kilowatt (kW)	Dough Capacity (kg)	Flour Capacity (kg)
	Width (A)	Depth (B)	Height (C)	Height (D)	Base Width (E)				
Twist60G	622	1049	1254	762	598	315	4.55	60	38
Twist90G	734	1274	1359	820	710	435	7	90	58
Twist130G	833	1271	1359	865	805	450	7	130	84
Twist160G	925	1392	1457	940	900	620	8.5	160	103
Twist200G	928	1450	1588	987	900	725	9	200	129
Twist250G	1080	1603	1588	980	1055	845	13.6	250	161
Twist300G	1080	1603	1588	1020	1055	845	13.6	300	193

**Electrical Requirements:**  
400-415V, 3P+E, 50Hz

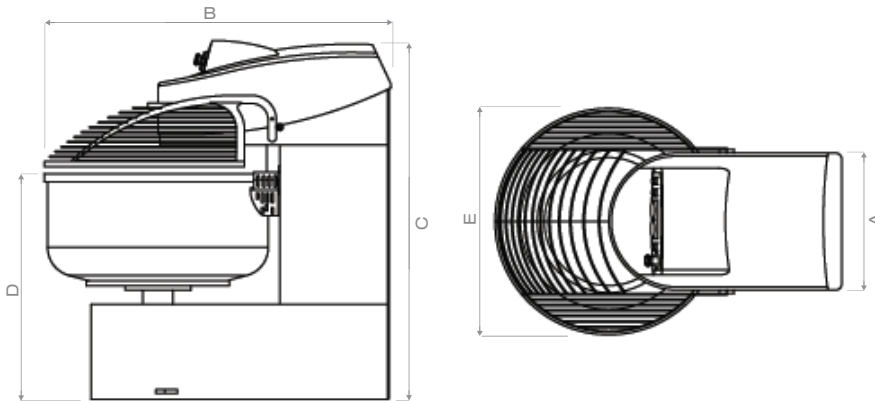

moffat.com.au  
moffat.co.nz

Australia  
moffat.com.au

Moffat Pty Limited

Victoria/Tasmania  
740 Springvale Road  
Mulgrave, Victoria 3170  
Telephone +613-9518 3888  
Facsimile +613-9518 3833  
vsales@moffat.com.au

New South Wales  
Telephone +612-8833 4111  
nswsales@moffat.com.au

South Australia  
Telephone +613-9518 3888  
vsales@moffat.com.au

Queensland  
Telephone +617-3630 8600  
qldsales@moffat.com.au

Western Australia  
Telephone +618-9413 2400  
wasales@moffat.com.au

New Zealand  
moffat.co.nz

Moffat Limited

Rolleston  
45 Illinois Drive  
Izone Business Hub  
Rolleston 7675  
Telephone +64 3-983 6600  
Facsimile +64 3-983 6660  
sales@moffat.co.nz

Auckland  
Telephone +64 9-574 3150  
sales@moffat.co.nz



In line with policy to continually develop and improve its products, Moffat Limited reserves the right to change specifications and design without notice. This specification sheet is meant for commercial purpose only. For technical documentation please refer to our service manuals.

© Copyright Moffat Ltd  
AN.S01.21

an Ali Group Company



The Spirit of Excellence