

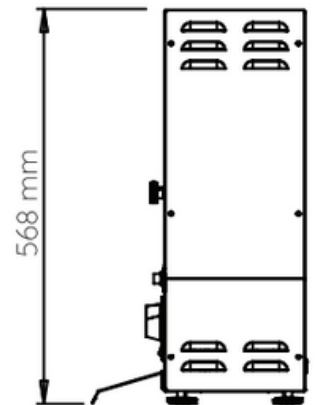

VERTICAL BUN TOASTER VCT1001

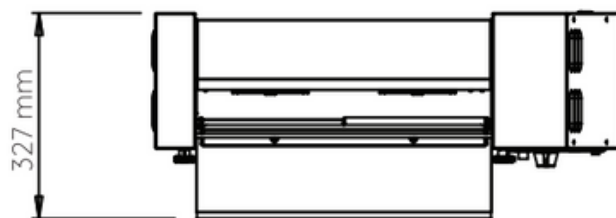

- Heavy duty stainless steel conveyor belt system
- Low noise operation
- Variable heat control 50°C to 300°C
- Slim design - small footprint
- Adjustable for various bun thicknesses
- 2.2kW element and an aluminium energy efficient heating plate for good heat distribution
- Single feed design
- Low energy consumption
- Precision cartridge bearing shafts
- Fast throughput - 22 buns per minute
- 1 x teflon release sheet that fits over plate element included

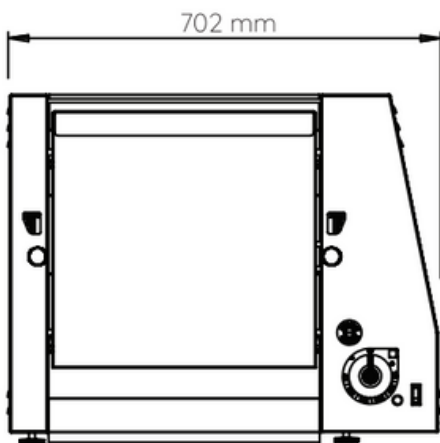

Specifications

Voltage: 240V

Power: 2.2kW

Size: 702 x 327 x 568mm

Weight: 27.6kg

Origin: South Africa

Warranty: 12 Months Warranty