

# S10, S15 & S20 Snack Master Small



Belt extension for easy loading



Individual temperature and speed controls

**The Snack Master Small is sized to fit on any benchtop, allowing for perfect toasting.**

**This super-efficient, easy loading compact conveyor is complete with belt extension for easy loading, individual controls for temperature adjustments and features a turbo fan cooling.**

**Toasting has never been easier.**



## FEATURES & BENEFITS

- 305mm belt width conveyor oven, ideal for toasting/cooking open snacks
- Smallest footprint of the Snackmaster range
- Available in either 10/15/20 Amp models
- Available with either energy efficient 'instant' heat infrared glass elements or metal heating elements
- Long cooking conveyor for easy loading
- Fan cooled controls and fan forced heat technology
- Independent temperature controls for top and bottom elements
- Variable speed belt control with automatic tensioning
- Stainless steel construction
- All models supplied with suitable plug and lead

W.CVS.SQI.xxx  
&  
W.CVS.S.xxx

## SPECIFICATIONS

10 / 15 / 20

kW 2.4 / 3.6 / 4.8    Amps 10 / 15 / 20

Width 900mm    Depth 445mm

Height 420mm

Oven Chamber Width 315mm

Oven Chamber Length 430mm

Oven Head Clearance 70mm

Dealer:

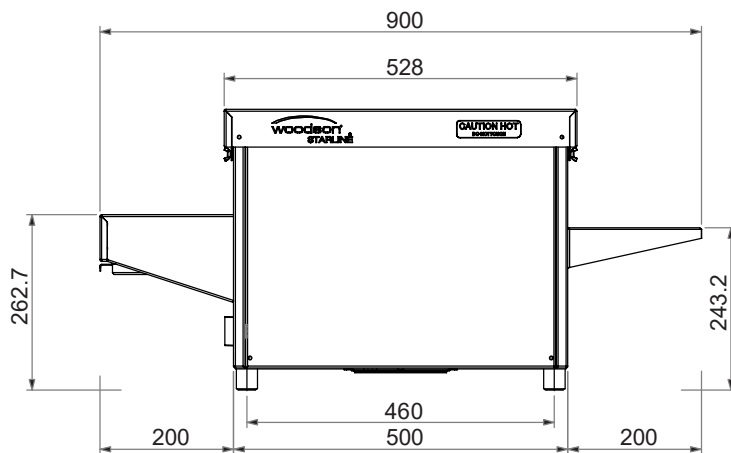
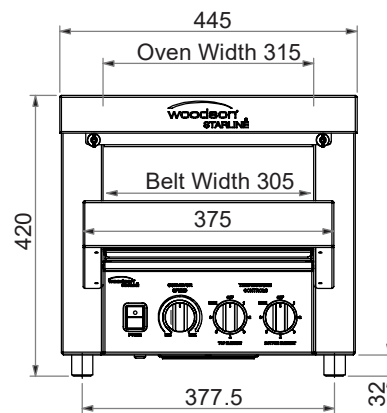

We reserve the right to alter specifications of products without notice. All dimensions are in mm.